



A DIVISION OF GETZ FIRE EQUIPMENT

**GETZ EQUIPMENT INNOVATORS
PART NO.: 3G59419
MODEL: BV 101 P
PNEUMATIC BELT VISE
WITH EXTENDED BELT & ROLLER**



2320 Lakecrest Drive, Pekin IL 61554
PH. (888) 747-4389 • Fax (309) 495-0625
Website: www.getzequipment.com

LIMITED WARRANTY

Getz Equipment Innovators warrants its products, and component parts of any product manufactured by Getz Equipment Innovators, to be free from defects in material and workmanship for a period of twelve (12) months from the date of purchase. During the warranty period, any such defects will be repaired or the defective parts replaced **(at Getz Equipment Innovators' option)**. The warranty does not cover defects resulting from modification, alteration, misuse, exposure to corrosive conditions, extremely high temperatures, improper installation or maintenance. Warranties on component items not manufactured by Getz Equipment Innovators are provided by others whose warranty, evaluation and judgment will be final.

All implied warranties, including, but not limited to, warranties of fitness for purpose and merchantability, are limited to the time periods as stated above. In no event shall Getz Equipment Innovators be liable to incidental or consequential damages. Some states do not allow limitations on how long an implied warranty lasts or the exclusions or limitation of incidental or consequential damages, so that the above limitations or exclusions may not apply to you. Getz Equipment Innovators neither assumes nor authorizes any representative or other person to assume for it any obligation or liability other than as expressly set forth herein.

Mobile Service Vehicles:

The warranty does not cover:

- Defects in the chassis and or power unit
- Defects in separately manufactured products not produced by Getz Equipment Innovators
- Deterioration due to normal wear, tear, and exposure
- Repairs made necessary by negligent use, misuse, abuse, loading the service vehicle beyond its gross vehicle weight limitations, accident, acts of God, or other contingencies beyond the control of Getz Equipment Innovators.
- Repairs deemed necessary by reason of the failure to follow ordinary maintenance procedures.
- Repairs deemed necessary by reason of alterations done without Getz Equipment Innovators' written approval.

Warranty Service:

- All warranty repairs will be performed by Getz Equipment Innovators in Pekin, IL, unless otherwise authorized by Getz Equipment Innovators.

Freight:

- Getz Equipment Innovators will not be liable for shipping or transportation charges to or from customer's location.

This warranty gives you specific legal rights, and you may also have other rights which vary from state to state. To obtain performance to the obligation of the warranty, write to Amerex Corp dba Getz Equipment Innovators, 2320 Lakecrest Drive, Pekin IL 61554, USA for instructions.

BELT VISE

PART NO.: 3G59419

TABLE OF CONTENTS

PAGE #

1	SPECIFICATIONS AND REQUIREMENTS
2	SET-UP AND OPERATION PROCEDURE
3	PARTS LIST
4	SCHEMATIC
5	SCHEMATIC
6	TROUBLE SHOOTING
7	SCHEMATIC
8	SCHEMATIC

SPECIFICATIONS AND REQUIREMENTS

SPECIFICATIONS:

HEIGHT - 38 INCHES (96.5 cm)

WIDTH – 16.75 INCHES (42.5 cm)

LENGTH – 27.25 INCHES (69 cm)

WEIGHT - 130 LBS (59 Kg)

SHIPPING WEIGHT - 154 LBS (70 Kg)

SHIPPING CONTAINER SIZE:

HEIGHT – 41.75 INCHES (106 cm)

WIDTH – 18.5 INCHES (47 cm)

LENGTH – 31.5 INCHES (80 cm)

REQUIREMENTS:

AIR SOURCE

1. CO2 VAPOR
2. NITROGEN
3. COMPRESSED AIR

MAXIMUM CYLINDER HOLDING DIAMETER:

Ø16 INCHES (40.6 cm)

OPTIONAL EQUIPMENT:

51957-SLIP JOINT DEVALVING WRENCH

"CAUTION"

1. THIS BELT VISE MUST HAVE A REGULATED AIR SOURCE OF NO MORE THAN 140 P.S.I.
2. OPERATOR MUST KEEP HANDS CLEAR OF THE BELT WHEN OPERATING THIS VISE.
3. OPERATOR MUST WEAR SAFETY GLASSES WHEN OPERATING THIS VISE.

SET-UP AND OPERATIONS

REFER TO SCHEMATIC

- STEP 1 - LOCATE THE BELT VISE IN AN AREA WHERE THE OPERATOR WILL HAVE ACCESS TO ADJUST THE BELT HANDLE (ITEM #20) AND ROOM TO DEVALVE THE CYLINDERS.
- STEP 2 - AFTER PLACEMENT OF THE BELT VISE, BOLT THE BASE PLATE TO THE FLOOR WITH LAG SCREWS OR BOLTS TO SECURE THE VISE FROM MOVING WHEN DEVALVING CYLINDERS.
- STEP 3 - REMOVE THE PLASTIC CONNECTOR (ITEM #19) FROM THE YELLOW AIR LINE (ITEM #7) AND THREAD TAPE OR PLACE SEALANT ON THE MALE PIPE THREADS.
- STEP 4 - SCREW THE PLASTIC CONNECTOR (ITEM #19) INTO THE OUTLET PORT ON YOUR REGULATOR AND RECONNECT THE YELLOW LINE (ITEM #7) TO THE PLASTIC CONNECTOR (ITEM #19).
- STEP 5 - PUSH THE AIR CONTROL VALVE HANDLE (ITEM #5) DOWN AND SET YOUR REGULATOR MIN. - 100 PSI TO MAX. - 140 PSI.
- STEP 6 - REMOVE THE BELT HANDLE (ITEM #20) FROM THE SLOTS IN THE BELT VISE AND ADJUST THE HORSE SHOE (ITEM #4) INTO THE PROPER HOLES FOR THE SIZE OF CYLINDER BEING DEVALVED.
- STEP 7 - PLACE THE CYLINDER TO BE DEVALVED ON TOP OF THE HORSE SHOE (ITEM #4) OR FOR LARGER CYLINDERS, REMOVE THE HORSE SHOE (ITEM #4) AND PLACE THE CYLINDER IN THE FRONT V OF THE BELT VISE.
- STEP 8 - REINSERT THE BELT HANDLE (ITEM #20) BACK INTO THE FARTHEST SLOT ON THE VISE THAT CAN BE REACHED.
- STEP 9 - REMOVE HANDS FROM BELT ON VISE AND PULL UP ON AIR CONTROL VALVE HANDLE (ITEM #5).
- STEP 10 - AFTER MAKING SURE NO PRESSURE IS IN THE CYLINDER BEING DEVALVED, PLACE YOUR DEVALVING WRENCH ON THE CYLINDER VALVE AND SCREW THE VALVE OUT OF THE CYLINDER.
- STEP 11 - PUSH DOWN ON AIR CONTROL VALVE HANDLE (ITEM #5) WHILE HOLDING ONTO THE CYLINDER, AND REMOVE THE BELT HANDLE (ITEM #20) FROM THE SLOT IN BELT VISE AND REMOVE THE CYLINDER.
- STEP 12 - FOLLOW STEP #6 THROUGH STEP #11 ON OTHER CYLINDERS.

PARTS LIST

<u>NO.</u>	<u>PART #</u>	<u>DESCRIPTION</u>	<u>QTY</u>
1	1G51835	STAND PEDESTAL ONLY	1
2	1G51725	PLATE RESTRAINING BELT	2
3	1G59417	BELT 53 WRAP AROUND ONLY	1
4	1G53611	HORSE SHOE EXTENDED	1
5	3G59484	VLV PUSH/PULL PARKER W/KNOB	1
6	1G51230	CONNECTOR PLAS 3/8 MPT X 1/4 TUBE	2
7	1G0047	MTL NYCOIL 1/4 YL	10 FT
8	1G0047	MTL NYCOIL 1/4 YL	1 FT
9	1G0047	MTL NYCOIL 1/4 YL	1 FT
10	1G51717	PLATE BACKING BELT	1
11, 12, 13, 22	1G0397	PNEUMATIC CYLINDER FOR BELT VISE	1
14	1G51791	SCREW SOCKET 1/2 X 2	1
15	3G58582	PAD CYL	1
16	1G51142	BOLT ELEVATOR 1/4 X 1	6
17	GRADE 5	BOLT HEX HEAD 1/4 X 1	4
18	1G51286	DECAL PANEL VISE	1
19	1G0136	CONNECTOR PLAS 1/4 ML X 1/4 TUBE	1
20	1G51378	HANDLE BELT	1
21	1G51878	TRAY TOOL	1
23	1G54432	CLEVIS MOUNT CYL BRACKET	1
24	GRADE 5	BOLT HEX HEAD 5/16 X 1 1/4	4
25	1G51583	NUT MOUNTING VALVE	1
26	1G53602	ROLLER VISE BELT	1
27	1G53594	BRACKET LOWER ROLLER	1
28	1G53595	BRACKET UPPER ROLLER	1

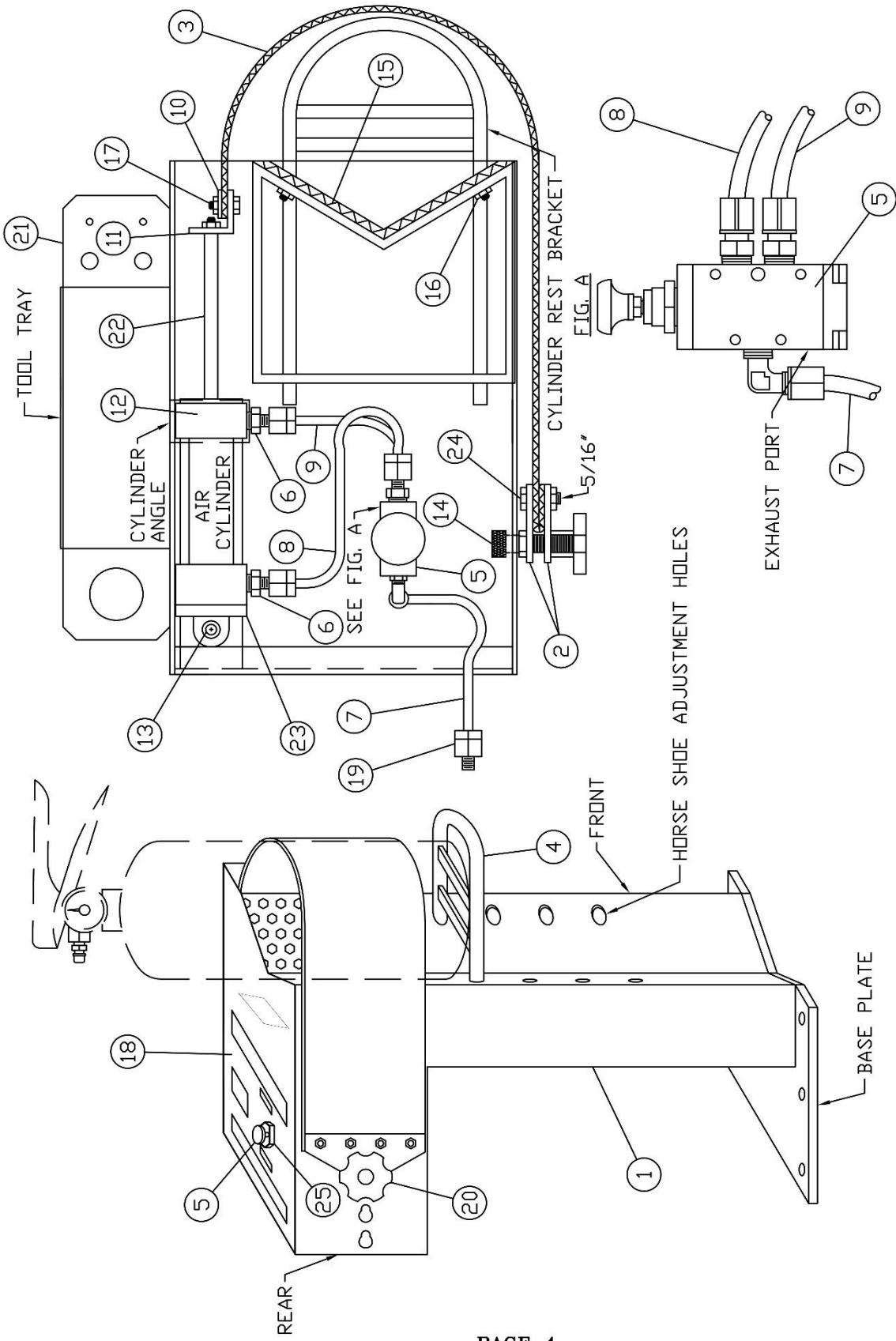

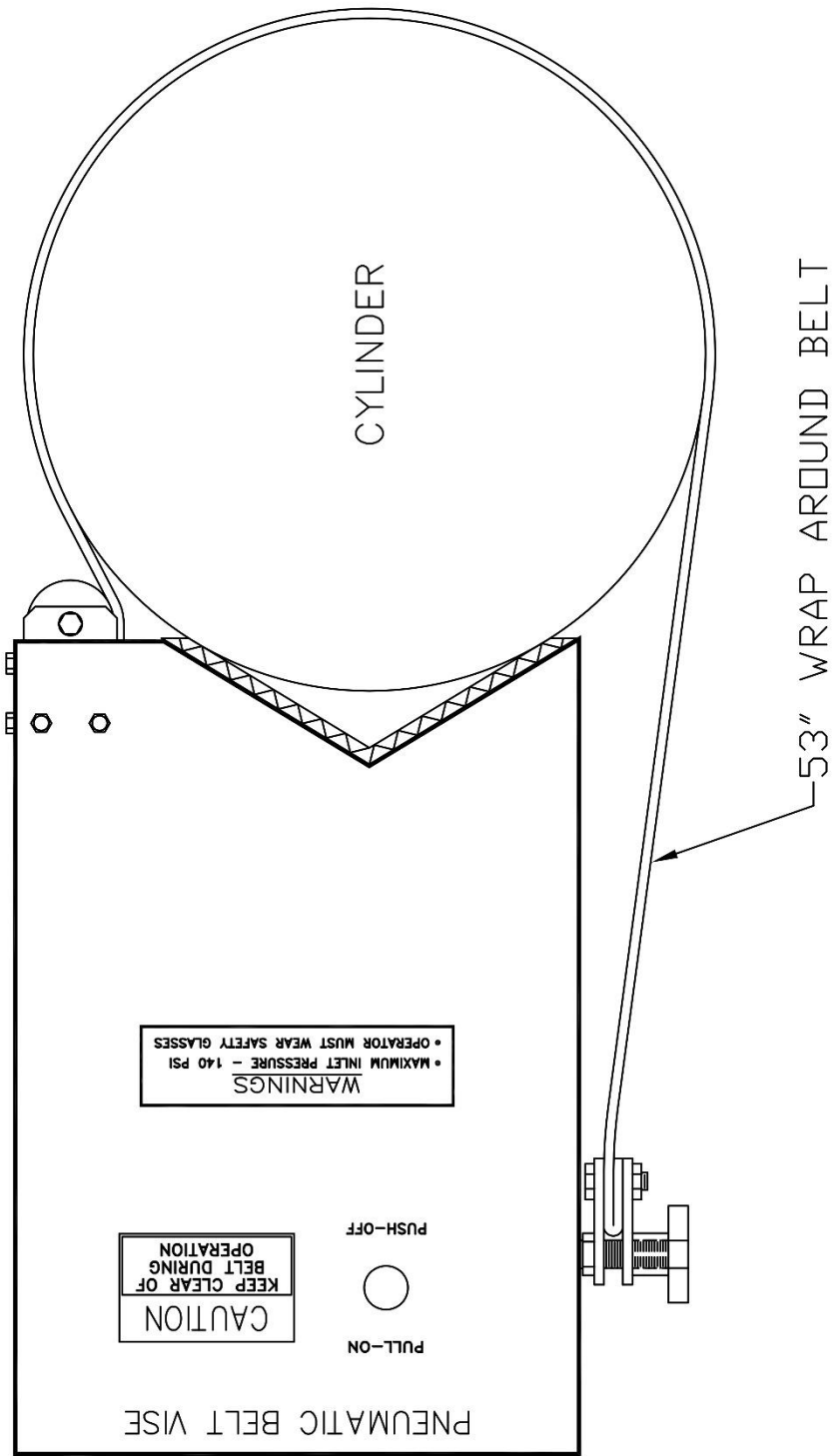

TROUBLESHOOTING

PROBLEM

SOLUTION

- | | |
|--|---|
| 1) VISE ISN'T HOLDING CYLINDER | 1) A) ADJUST PRESSURE TO 100-140PSI
B) CHECK FOR AIR LEAKS & REPAIR |
| 2) AIR LEAK IN CONTROL VALVE | 2) REPLACE VALVE- P/N: 3G59484 |
| 3) AIR LEAK IN AIR CYLINDER BODY | 3) REPLACE AIR CYLINDER - P/N: 1G0397 |
| 4) AIR BLOWS OUT EXHAUST PORT
ON AIR VALVE CONTINUOUSLY | 4) REPLACE AIR CYLINDER - P/N: 1G0397 |
| 5) BELT BROKEN, WORN, OR TORN | 5) REPLACE BELT- P/N: 3G59417
REPLACE BELT ASSEMBLY
-P/N: 3G59405 |
| 6) BENT AIR CYLINDER SHAFT | 6) REPLACE AIR CYLINDER - P/N: 1G0397 |

USE THE FOLLOWING KIT FOR GENERAL SERVICE AND MAINTENANCE- P/N: 3G58895

