



A DIVISION OF GETZ FIRE EQUIPMENT

**Getz Equipment Innovators  
150# Optimum Poly Fill System  
Part No: 3G0031OPT**

Revised 1/26/18



2320 Lakecrest Drive, Pekin, Illinois 61554  
Telephone: 888-747-4389 Fax: 309-495-0625  
Website: [www.getzequipment.com](http://www.getzequipment.com)

**EQUIPMENT INNOVATORS**

## Limited Warranty

Products manufactured by Getz Equipment Innovators (with exception of electrical products or components) will be free from defects for a period of one year from shipment date. Electrical products and/or components used in manufactured products will have a (6) month warranty from shipment date. During the warranty period, customers who experience any manufacture-related service issues with our products, the product may be returned for repair or replacement. Customer must contact Getz Equipment for approval prior to any product return. Notwithstanding the foregoing, the limited warranty set forth shall be immediately void of customer uses any replacement parts other than those provided by Getz Equipment Innovators. The warranty does not cover normal wear and tear items, defects resulting from modification, alteration, misuse, exposure to corrosive conditions, extremely high temperatures, improper installation or maintenance. Warranties on component items not manufactured by Getz Equipment Innovators are provided by others whose warranty, evaluation and judgment will be final.

All implied warranties, including, but not limited to, warranties of fitness for purpose and merchantability, are limited to the time periods as stated above. In no event shall Getz Equipment Innovators be liable to incidental or consequential damages. Some states do not allow limitations on how long an implied warranty lasts or the exclusions or limitation of incidental or consequential damages, so that the above limitations or exclusions may not apply to you. Getz Equipment Innovators neither assumes nor authorizes any representative or other person to assume for it any obligation or liability other than as expressly set forth herein.

### **Mobile Service Vehicles:**

The warranty does not cover:

- Defects in the chassis and or power unit
- Defects in separately manufactured products not produced by Getz Equipment Innovators
- Deterioration due to normal wear, tear, and exposure
- Repairs made necessary by negligent use, misuse, abuse, loading the service vehicle beyond its gross vehicle weight limitations, accident, acts of God, or other contingencies beyond the control of Getz Equipment Innovators.
- Repairs deemed necessary by reason of the failure to follow ordinary maintenance procedures.
- Repairs deemed necessary by reason of alterations done without Getz Equipment Innovators' written approval.

Warranty Service:

- All warranty repairs will be performed by Getz Equipment Innovators in Pekin, IL, unless otherwise authorized by Getz Equipment Innovators.

Freight:

- Getz Equipment Innovators will not be liable for shipping or transportation charges to or from customer's location.

This warranty gives you specific legal rights, and you may also have other rights which vary from state to state. To obtain performance to the obligation of the warranty, write to Getz Equipment Innovators, 2320 Lakecrest Drive, Pekin IL 61554, USA for instructions.

# Getz Equipment Innovators Dry Chemical Fill System

## Table of Contents

### Page

1	.....	Getz Filling System
2	.....	Drawing # 1 – Control Console
3	.....	Drawing #2 – Console, Inside View
4	.....	Drawing #3 – Console, Inside View
5	.....	Drawing #4 – Fill System, Exterior View
6	.....	Assembly Instructions
7	.....	Procedure for Discharging & Filling Fire Extinguisher
8	.....	Trouble Shooting
9	.....	Recommended Maintenance

# **Getz Filling System**

## **MOTIVE POWER SOURCE**

Air Compressor  
Compressed Air  
Nitrogen  
CO2 Vapor \*

**\* Customer must remove the syphon tube from the supply valve of the liquid CO2 tank to have vapor.**

To get maximum vacuum on your fill system, the operating input pressure may range from 40 to 55 P.S.I. To set your regulator for the best results, take the vacuum line off the elbow connector screwed into the filler tube. Turn the on-off switch on and put your finger over the vacuum line. Then, adjust the regulator up or down as needed, so that you have maximum vacuum on your gauge.

## **Shipping Size of container and weight**

23" X 23" X 38 – 50 LBS

**Warning: Operator must wear safety glasses when operating filling system equipment**

# Drawing 1

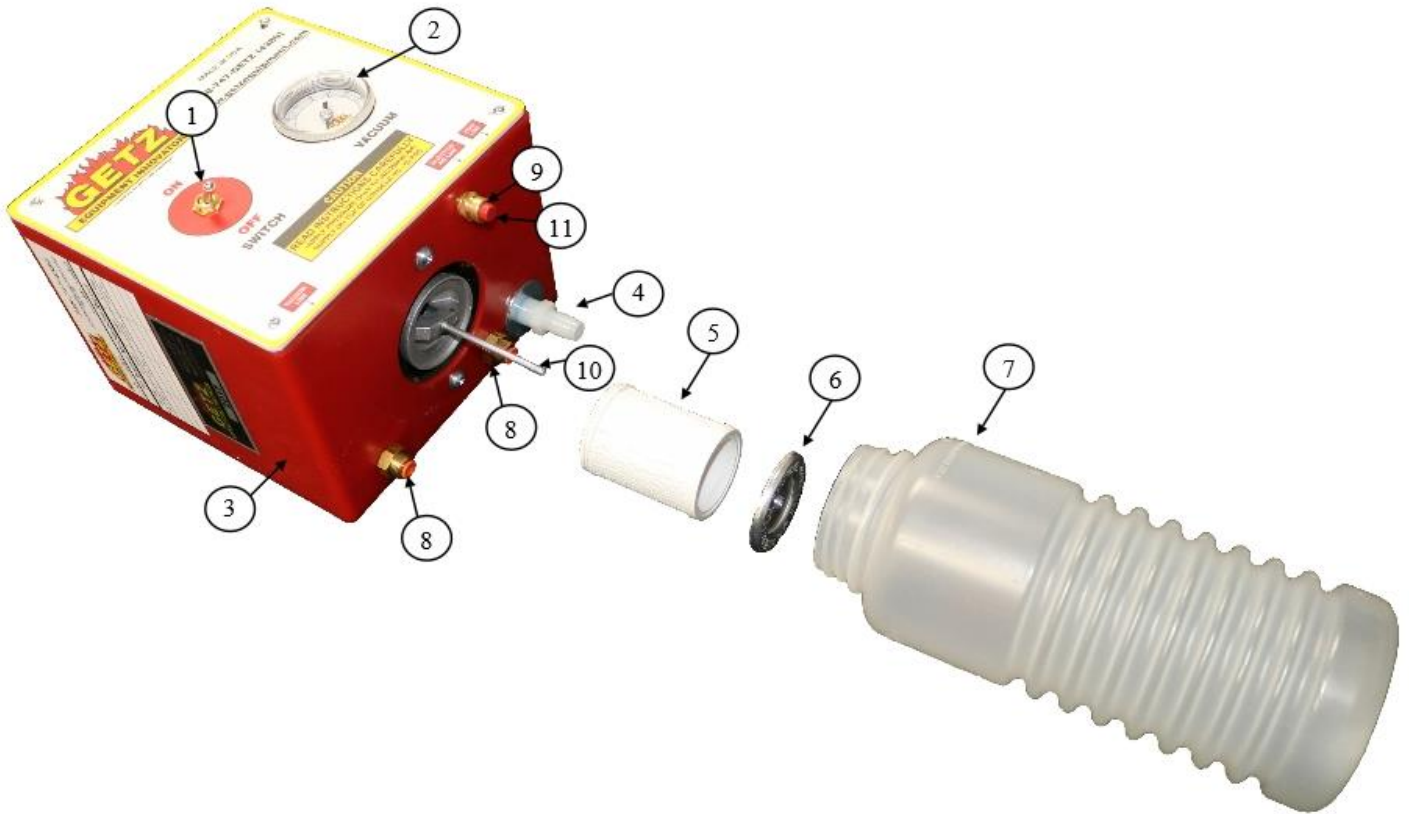

**DRAWING 1**

ITEM NO.	PART NUMBER	DESCRIPTION	QTY.
1	1G0015	TOGGLE VALVE 3 WAY	1
2	1G0018	GAUGE 30" VACUUM 2" DIAL	1
3	1G0023/1G0125	CONTROL CONSOLE PLASTIC BOX/LID	1
4	1G54339	HOSE BARB PLASTIC ½ X ¼ FEMALE	1
5	1G0067	JAR FILTER	1
6	1G0067	FILTER CAP	1
7	1G0020	JAR PLASTIC RIBBED	1
8	1G0197	BULKHEAD UNION ¼ - ¼ TUBE	2
9	1G0325	PUSH BUTTON VALVE AIR INJECTION	1
10	1G0117	FILTER HOUSING ASSEMBLY	1
11	1G0326	PUSH BUTTON COVER RED AIR INJECTION	1

# Drawing 2 - Inside View



**DRAWING 2**

1	1G0015	TOGGLE VALVE 3 WAY	1
2	1G0201	TEE SWIVEL ¼ TUBE TO 1/8 NPT	1
3	1G0200	TEE ADAPTER SWIVEL ¼ OD TUBE	1
4	1G0046	TUBING POLY ¼ RED	2
5	1G0047	TUBING POLY ¼ YELLOW	3
6	1G0048	TUBING POLY ¼ WHITE	1

**Please order replacement parts from:**

**Getz Equipment Innovators**

**Pekin, IL 61554**

**Phone (888) 747-GETZ (4389)**

**Fax (309) 309-495-0625**

**[www.getzequipment.com](http://www.getzequipment.com)**

## Drawing 3 - Inside View

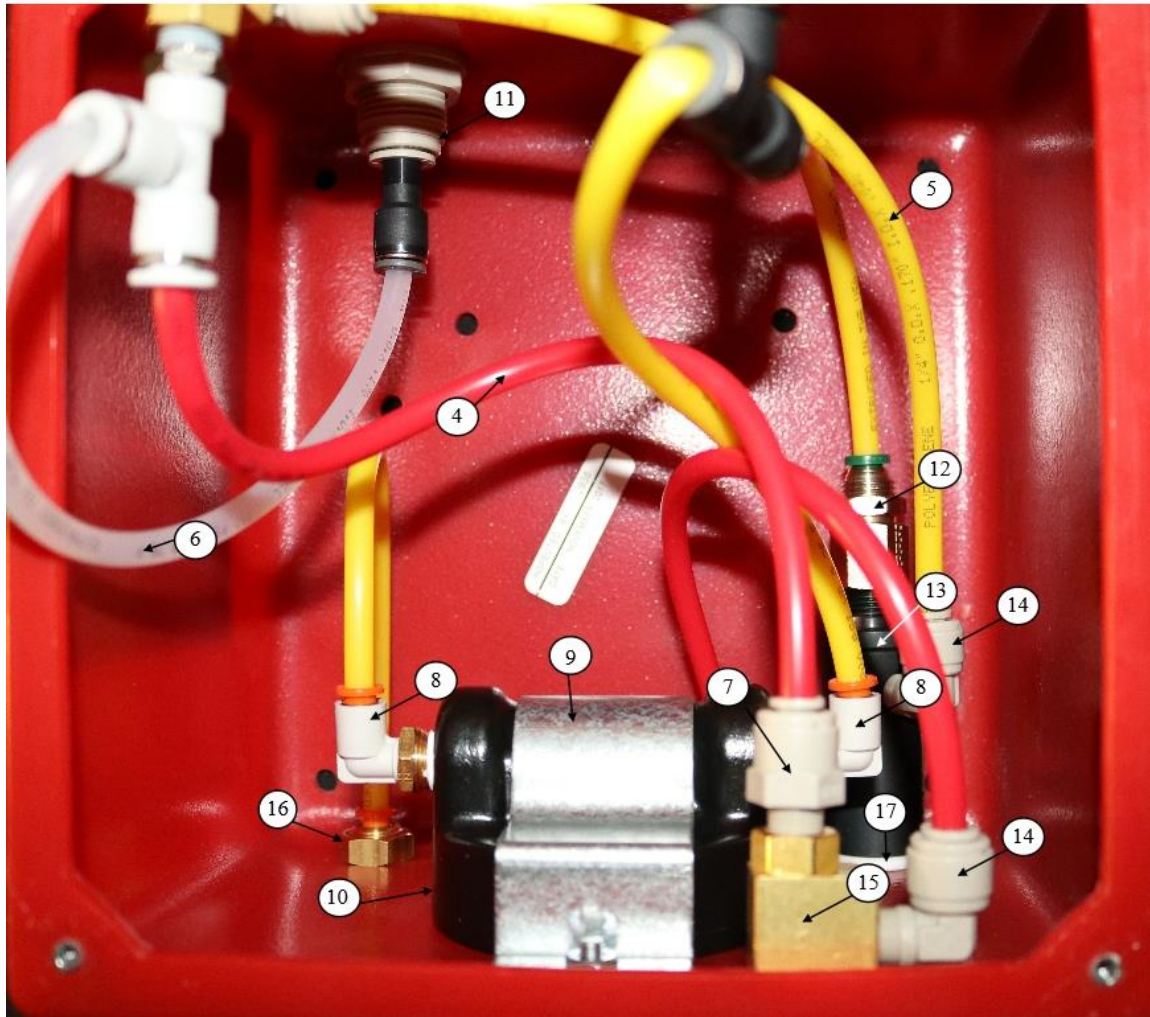

4	1G0046	TUBING POLY ¼ RED	2
5	1G0047	TUBING POLY ¼ YELLOW	3
6	1G0048	TUBING POLY ¼ WHITE	1
7	1G0199	ADAPTER STRAIGHT ¼ TUBE – 1/8 NPT	1
8	1G0198	ELBOW 90 ¼ STEM TO ¼ TUBE	2
9	1G0011	JAR BRACKET ASSEMBLY	1
10	1G0017	FILTER HOUSING ASSEMBLY	1
11	1G0193	BULKHEAD UNION 3/8 – ¼	1
12	1G0168	BULKHEAD FEMALE ¼ NPT X ¼ PTC	1
13	1G54400	VENTUR WHEELED UNIT	1
14	1G0327	ELBOW 90 ¼ OD X 1/8 NPT	3
15	1G0325	PUSH BUTTON VALE AIR INJECTION	1
16	1G0197	BULKHEAD UNION ¼ - ¼ TUBE	2
17	1G51344	GASKET FILL AD TEFLON	1

# Drawing 4 – Exterior View



ITEM NO.	PART NUMBER	DESCRIPTION
25	1G0032	FILL LINE - TUBING 1/2 I.D. CLEAR VINYL PER FT.
26	1G0033	DISCHARGE LINE - TUBING 1/2 REINFORCED CLEAR VINYL PER FT
27	1G0084	VALVE BALL 1/2" BRASS
28	1G0048	VACUUM LINE - TUBING POLY 1/4 WHITE
29	1G0091	CONE FILL TUBE RUBBER
30	3G0036	CONSOLE
31	1G0020	JAR
32	1G0046	AIR INJECTION LINE - TUBING POLY 1/4 RED
33	1G0012	LID HOPPER PLASTIC
34	1G0034	LEVER LOCK RING FOR HOPPER
35	1G0024	HOPPER FILTER
36	N/A	HOPPER
37	1G0028	COUPLING FEMALE STRAIGHT-THRU 1/4
38	N/A	PLASTIC STAND



## Assembly Instructions

1. Remove Filling System from shipping container
2. Remove lid and filter by releasing the band assembly and inside you will find an assortment of hoses and the console.
3. Remove all items from inside the hopper.
4. Separate the red stand from the hopper.
5. If filling system is to be placed in a vehicle then it will need to be mounted to the floor using (4) 5/8 X 3" bolts (8) fender washers (top and underside of vehicle) and (4) nylon locking nuts (hardware not included). If it is for shop use then mounting the base to the floor is optional. When mounting make sure the vertical sight slot is in front. Leave at least a 4" clearance around the base from any wall or structure.
6. Attach the clear 1/2" vinyl tubing (line with black cone) to the 45 degree outlet at the base of the hopper; attach using provided worm gear clamp. Feed the clear vinyl tubing through the left front opening in the bottom of the stand.
7. Attach long end of the red 1/4" poly tubing to the air injection port on the right side of the hopper by pushing it firmly into the connector. Feed the short end of the red 1/4" poly tubing through the right rear opening at the bottom of the stand. Place the hopper back into stand with the logo and bulk head assembly in front.
8. Mount console to wall centering it above the filling system approximately 36" above the floor. Use the two mounting brackets on top of the console.
9. Attach the 6' clear 1/2" vinyl tubing to the vent line port on the base of the console on the right side by pushing it over the hose barb. It is best if the vent line goes through the floor of the vehicle or directed to an exhaust fan.
10. Attach red 1/4" poly tubing to the air injection port on the base of the console (right side) by pushing it firmly into the connector.
11. Mount ring bracket onto the wall next to the console approximately 46" from the floor.
12. Unscrew rubber cone from filler tube. Bring filler tube and 1/2" clear vinyl up through the bottom of the ring bracket. Screw rubber cone back onto filler tube.
13. Attach white 1/4" poly tubing to the vacuum port on the base of the console (left side) by pushing it firmly into the connector.
14. Screw the discharge line (braided line with 1/2" ball valve) into the black bulkhead on the front of the hopper
15. Connect 3/8" white poly tubing to the fitting on the top of the console by pushing the air line into the fitting. Attach opposite end of 3/8" tubing to air compressor or regulator. Maximum incoming air should be no more than 55 psi.

## **Portable Extinguisher Discharge Instructions**

1. Make sure extinguisher is pressurized.
2. If extinguisher is not pressurized and is full/partially full of chemical, hook up re-charge adapter and pressurize to factory recommended pressure on gauge.
3. Remove hose and connect correct discharge adapter with male quick coupler into valve assembly of extinguisher.
4. Connect discharge assembly coupling (Item #37, Drawing #4) to the discharge adapter on extinguisher.
5. Ensure that powder recovery lid is clamped firmly to hopper.
6. Close valve (Item #27, Drawing #4) and partially discharge extinguisher into the discharge hose (Item #26, Drawing #4) to inspect chemical.
7. If chemical is proper chemical for extinguisher being discharged, open valve (Item #27, Drawing #4) to allow chemical into hopper and allow nitrogen pressure to escape through the powder recovery filter.
8. Discharge extinguisher and when pressure gauge reaches zero, disconnect discharge assembly hose and inspect or hydro-test the extinguisher.
9. Remove valve from extinguisher and clean.
10. Perform 6 year internal maintenance, recharge or hydro-test.

## **Filling Empty Dry Chemical Extinguisher Instructions**

1. Ensure that scale is set and balanced to zero.
2. Visually check with inspection light that empty dry chemical extinguisher is dry and not corroded.
3. Check for type of chemical to be filled on label of empty extinguisher.
4. The filling lines are colored yellow (ABC) and white (BC chemical).
5. Take clear fill line and extend it to the top of the empty cylinder to be filled.
6. Place rubber cone (from the end of fill line) into top of cylinder neck with a clockwise  $\frac{1}{4}$  turn.
7. With extinguisher and fill line attached on scale, return scale back to zero (making it "weightless") and then fill to recommended weight.
8. Turn off-on valve to "ON" position until extinguisher reaches recommended weight. Turn valve to "OFF" once it is filled. \*\*If chemical returns to plastic jar before reaching correct weight, let it settle then turn valve back on to reach desired weight.
9. Remove fill line from neck to fill line ring bracket.

## **Trouble Shooting for Fill System**

To determine if problem is in console, take the vacuum line (Item #28, Drawing #4) off of the elbow connector screwed into the filler tube. Turn the on-off switch (Item #1, Drawing #2) on and put your finger over the vacuum line (item #28). Suction should be present and gauge should read a minimum 15" of vacuum. IF NOT, make sure jar gasket is in place and make sure jar (Item #7, Drawing #1) is tight against gasket.

**DO NOT blow air through console or jar assembly.**

If there is suction at the end of the vacuum line (Item #28, Drawing #4), the trouble is NOT in the console. Most problems are commonly outside the console such as: lumpy chemical, moist chemical or a plugged fill hose.

**If the console is not working properly, it is recommended to clean or replace the *venturi* (Item #13, Drawing #3).**

1. Chemical will not flow when:
  - a. Extinguisher is not vacuum tight (i.e. a cartridge extinguisher with leaky cartridge receiver).
  - b. There is a kink in a hose.
  - c. The fill line and/or vacuum line are clogged.
  - d. Jar filter assembly on console is not properly sealed (must be tight).
  - e. Air supply is not regulated and maintained at 40 – 55 PSI
2. Overflow jars located under console should never be allowed to fill more than halfway before emptying.
  - a. Filter element in jars may be blown clean with an air gun (or similar tool) weekly.
  - b. Replace filter every six months.

## **Recommended Maintenance**

Getz Equipment Innovators has designed their plastic dry chemical fill systems to be the most maintenance-free available and to provide the longest equipment life. Nevertheless all equipment needs maintained and simple steps can be done to assure your fill system(s) continues to operate at optimum performance. To maintain optimum fill system performance we recommend the following maintenance items at a minimum. These recommendations are based on averages so frequencies may vary depending on number of extinguishers serviced using the dry chemical fill system(s).

### **Daily**

- Empty the plastic overflow jar when dry chemical reaches the line marked on the jar. Allowing the dry chemical to go above the line on the jar will allow chemical to flow back into the console tubing causing damage to the venturi, on/off valve, and vacuum gauge.

### **Weekly**

- Clean Hopper Lid Filter. Vacuum the inside of the filter. If there is dry chemical caked onto the filter it needs to be replaced.
  - Clean Jar Filter. Use only 10-15 psi to blow and clean the jar filter.
  - Discharge Hose. Look for burn/soft spot at end by coupling and replace when worn

### **Annually (See Instructions Below)**

- Replace Hopper Lid Filter
  - Replace Jar Filter
  - Replace Jar Gasket
  - Clean Venturi

## **Maintenance Kit Instructions**

<https://www.youtube.com/watch?v=WDXCNaJ1Ud4>

### **1G0024 - Hopper Lid Filter (See Drawing #3)**

1. Unlatch the hopper lever lock ring (Item #34) and remove with the plastic hopper lid (Item #33).
2. Remove old hopper lid filter (Item #35) and discard.
3. Install new hopper lid filter and reinstall plastic hopper lid (beveled edge on top) and lever lock ring.

### **1G0067 – Jar Filter & 1G00205 – Jar Gasket**

4. Unscrew the Plastic Jar (Item #7, Drawing #1) counterclockwise from the bottom of the console and the metal Filter Cap (Item #6, Drawing #1). The Jar Filter (Item #5, Drawing #1) should be loose to remove after the metal Filter Cap is removed.
5. Remove the old Jar Gasket. Gently clean the Filter Housing Assembly (Item #10, Drawing 3) being careful not to blow air up into the Housing/Console that will force chemical into the tubing.
6. Install the new Jar Gasket and new Jar Filter with the metal Filter Cap. Install the Plastic Jar.