

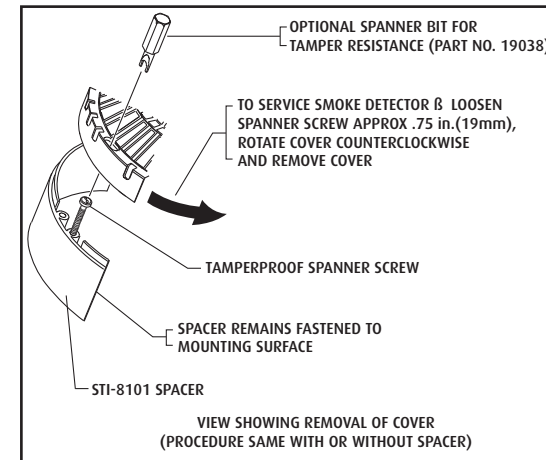

**Safety Technology International, Inc.**  
 2306 Airport Road • Waterford, Michigan 48327-1209  
 Phone: 248-673-9898 • Fax: 248-673-1246  
 Toll Free: 800-888-4784 • E-mail: info@sti-usa.com  
 Web: www.sti-usa.com

**Safety Technology International Ltd**  
 Taylor House • 34 Sherwood Road • Bromsgrove  
 Worcestershire • B60 3DR • England  
 Tel: +44 (0)1527 520 999 • Fax: +44 (0)1527 501 999  
 E-mail: info@sti-emea.com • Web: www.sti-emea.com

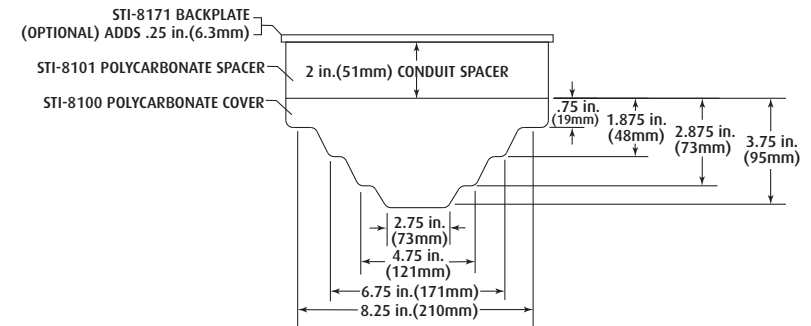
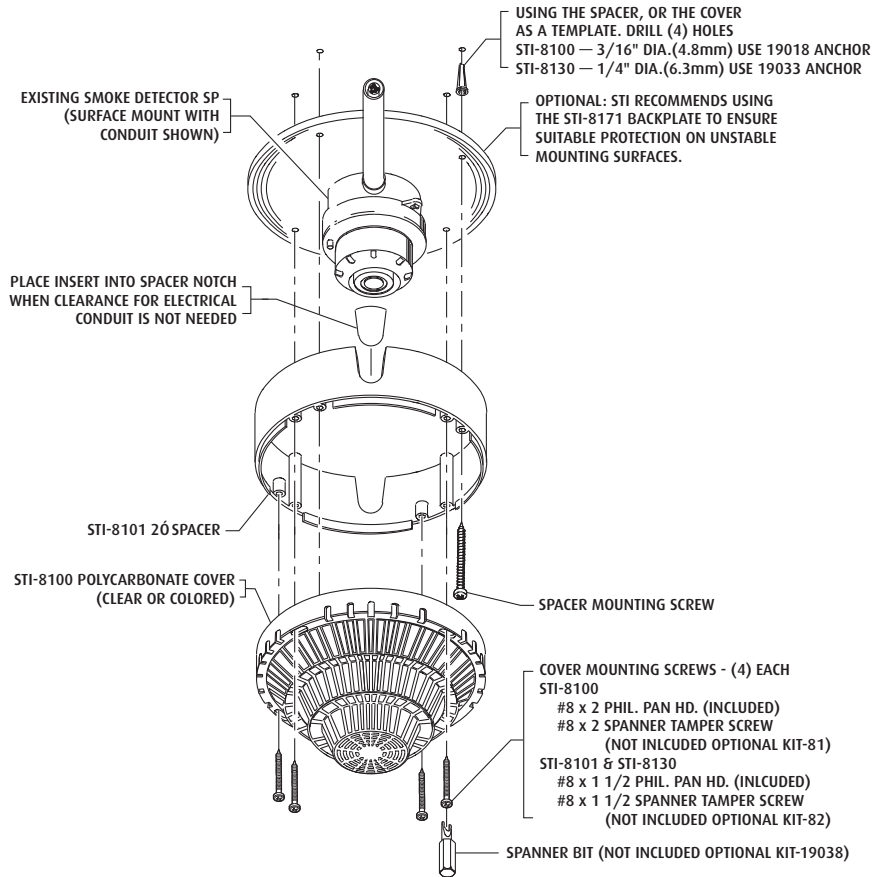

**NOTES**

1. STI-8130 consists of (1) STI-8100 cover & (1) STI-8101 Spacer including all standard mounting hardware.
2. Installer shall follow NFPA 72 National Fire Alarm code (protective signalling systems) for installation testing and maintenance.
3. Do not paint this product. Painting may obstruct the flow of the smoke to the detector.
4. When installing STI-8100 guard with Siemens detectors, sensitivity adjustment is mandatory. See Siemens' detector install sheet.

**Three year warranty or a one year limited warranty (from date of purchase) on most products. See website for details. Electronic warranty form at [www.sti-usa.com/wc14](http://www.sti-usa.com/wc14).**

**APPROVALS**

**STI-8100 & STI-8130 GUARDS**

Sentrol smoke detector models: 611UD, 612UD, 721UD, & 731UD under 300 Fpm.

**STI-8100 GUARD ONLY**

STI-8100 UL Listed No. S3504 for use with the following smoke detectors: System Sensor Models 2251, 2251T, 2251B, 2251TB, 2251TM, 2251TMB, 2251BR, 2551, 2551T, FTX-P1, FCI Models ASD-PL, ASD-P, ASD-PH, ASD-PTL, ASD-FILTEREX, ASD-FILTREXF, MCS-ACCLIMATE, ASD-PL2, ASD-PL2F, ASD-PTL2, ASD-PTL2F, MCD-ACCLIMATE2, MCS-ACCLIMATE2F, ASD-PL2FR, Secutron Models MRI-2251, MRI-2251B, EST Models 2251F, 2251FB, Mircom Models MIX-2251, MIX-2251B, Intelligent Systems Model ISL 2251, JCI Model 2951J, ADT Model 2951ADT, Fire-Lite Model SD355, Gamewell Model SS-P, Honeywell Models TC806B1076, TC806B1001 under 300 Fpm, Notifier Model FSP-751, FSP-851 and Siemens Models PE-11, FP-11, FPO-11, HFP-11, HFPO-11, DB-11.



**INSTALLATION OF STI-8100/STI-8130 SMOKE DETECTOR DAMAGE STOPPER®**

All specifications and information shown were current as of publication and are subject to change without notice.