

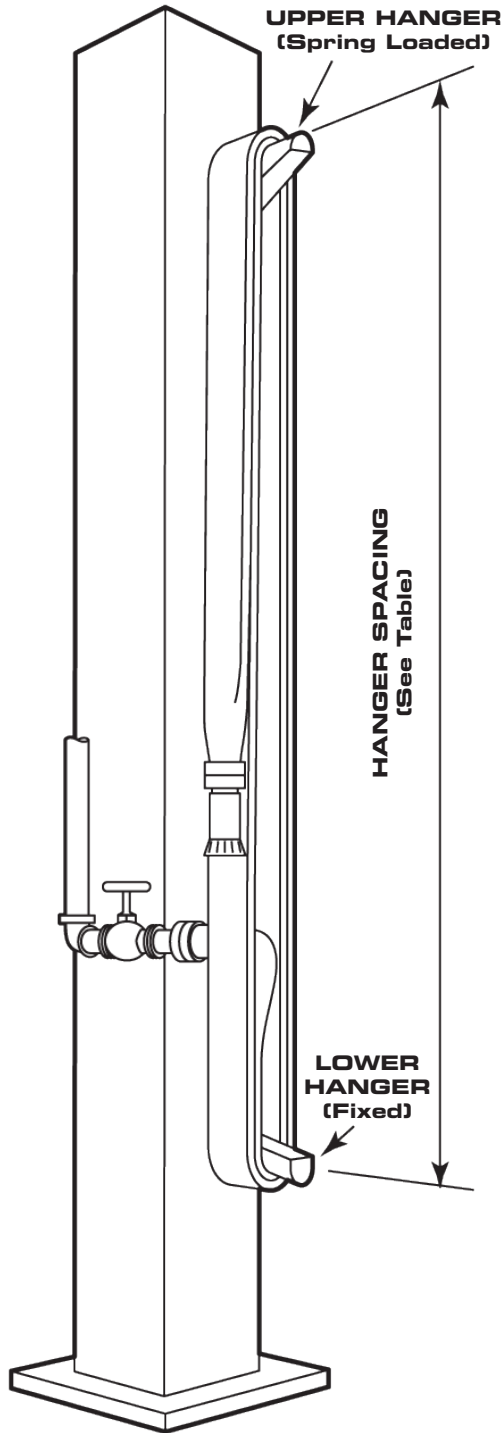

# Hose Hanger



**FireTech™ HOSE HANGERS** are constructed of aluminum alloy and conveniently accommodate lined or unlined hose, up to 2½". The top shoulder is spring loaded so that water pressure or a single pull is sufficient to release the hose. It also stores hose close to walls or columns to minimize damage as well as allowing for fewer bends in the hose, prolonging its life.

## FEATURES

- Hose instantly releases with a single pull
- Keeps hose close to walls or columns, minimizing damage from forklifts, etc.
- Fewer bends and larger radii prolong life of hose
- Low cost and easy to install

		Total Loops Of Hose		
		2	3	4
Hose Length	50'	12'	8'	6'
	75'		12'	9'
	100'			12'