



A DIVISION OF GETZ FIRE EQUIPMENT

**Getz Equipment Innovators  
Dry Chemical Fill  
System – Industrial  
Part No: 3G0086**

Revised 11/16/10



2320 Lakecrest Drive, Pekin IL 61554  
PH. (888) 747-4389 • Fax (309) 495-0625  
Website: [www.getzequipment.com](http://www.getzequipment.com)

## LIMITED WARRANTY

Getz Equipment Innovators warrants its products, and component parts of any product manufactured by Getz Equipment Innovators, to be free from defects in material and workmanship for a period of twelve (12) months from the date of purchase. During the warranty period, any such defects will be repaired or the defective parts replaced **(at Getz Equipment Innovators' option)**. The warranty does not cover defects resulting from modification, alteration, misuse, exposure to corrosive conditions, extremely high temperatures, improper installation or maintenance. Warranties on component items not manufactured by Getz Equipment Innovators are provided by others whose warranty, evaluation and judgment will be final.

All implied warranties, including, but not limited to, warranties of fitness for purpose and merchantability, are limited to the time periods as stated above. In no event shall Getz Equipment Innovators be liable to incidental or consequential damages. Some states do not allow limitations on how long an implied warranty lasts or the exclusions or limitation of incidental or consequential damages, so that the above limitations or exclusions may not apply to you. Getz Equipment Innovators neither assumes nor authorizes any representative or other person to assume for it any obligation or liability other than as expressly set forth herein.

### **Mobile Service Vehicles:**

The warranty does not cover:

- Defects in the chassis and or power unit
- Defects in separately manufactured products not produced by Getz Equipment Innovators
- Deterioration due to normal wear, tear, and exposure
- Repairs made necessary by negligent use, misuse, abuse, loading the service vehicle beyond its gross vehicle weight limitations, accident, acts of God, or other contingencies beyond the control of Getz Equipment Innovators.
- Repairs deemed necessary by reason of the failure to follow ordinary maintenance procedures.
- Repairs deemed necessary by reason of alterations done without Getz Equipment Innovators' written approval.

Warranty Service:

- All warranty repairs will be performed by Getz Equipment Innovators in Pekin, IL, unless otherwise authorized by Getz Equipment Innovators.

Freight:

- Getz Equipment Innovators will not be liable for shipping or transportation charges to or from customer's location.

This warranty gives you specific legal rights, and you may also have other rights which vary from state to state. To obtain performance to the obligation of the warranty, write to Getz Equipment Innovators, 2320 Lakecrest Drive, Pekin IL 61554, USA for instructions.

# Getz Equipment Innovators Dry Chemical Fill System - Industrial

## Table of Contents

### Page

3	.....	Getz Filling System
4	.....	Parts List
5	.....	Drawing #2 – Console & Filter Assembly
6	.....	Drawing #3 – Console Lid Interior
7	.....	Parts List
8	.....	Drawing #3 – General Arrangement
9	.....	Assembly Instructions
9	.....	Trouble Shooting & Service Aids
10	.....	Recommended Spare Parts Kit
11	.....	Maintenance Kit Instructions

## Getz Industrial Filling System

Power Source:

Air Compressor  
Compressed Air  
Nitrogen  
CO2 Vapor \*

\* Customer must remove siphon tube from the supply valve of the liquid CO2 tank to have vapor, and attach an in line moisture trap. (sold separately)

To get maximum vacuum on your fill system, the operating input pressure may range from 60 to 80 P.S.I. To set your regulator for the best results, take the vacuum line (item #29) off of the elbow connector screwed into the filler tube. Turn the on-off switch (item # 7) on and put your finger over the vacuum line (item #29). Then, adjust the regulator up or down as needed, so that you have maximum vacuum on your gauge.

### **Shipping Size of container and weight**

23" X 23" X 38 – 50 LBS

**Warning: Operator must wear safety glasses when operating filling system equipment**

### Caution

- **When discharging industrial cylinders or any pressurized cylinder over 300 PSI, the Black Discharge Hose (item #29) pictured on page 8 must be used.** (If you want to discharge regular portable fire extinguishers using this system you will need a separate discharge line, part number 3G0016.)
- **The safety relief on the rear of the hopper should never be removed for any reason.**

### DRAWING 1

ITEM NO.	PART NUMBER	DESCRIPTION	QTY.
1	1G0020	PLASTIC JAR	1
2	1G0206	FILTER CAP	1
3	1G0067	JAR FILTER	1
4	3G0082	PUSH BUTTON W/RED COVER – AIR INJECTION	1
5	1G0205	JAR GASKET	1
6	N/A	JAR BRACKET SCREWS	2
7	1G0015	VALVE 3 WAY TOGGLE	1
8	N/A	CONSOLE LID	1
9	1G0193	BULKHEAD UNION 3/8-1/4 TUBE, M20. OX1.5	1
10	1G0018	GAUGE 30" VACUUM 2" DIAL	1
11	1G0065	UNION BULKHEAD 1/2" PLASTIC	1
12	1G0207	STEM	1
13	1G0197	BULKHEAD UNION 1/4-1/4 TUBE	2

### DRAWING 2

14	1G0047	TUBING POLY 1/4 YELLOW	1 ft
15	1G0198	90 ELBOW 1/4" STEM TO 1/4" TUBE	2
16	1G0199	STRAIGHT ADAPTER 1/4" TUBE -1/8" NPT	1
17	1G0201	SWIVEL SIDE TEE 1/4" TUBE TO 1/8" NPT	1
18	3G0151	VENTURI TEE 1/4 TUBE BRASS	1
19	1G0041	CLAMP 2 - EAR 3/4"	2
20	1G0099	ELBOW POLY BARBED 1/2 X 1/2	1
21	1G0032	TUBING 1/2 I.D. CLEAR VINYL PER FT.	7
22	1G0200	SWIVEL TEE ADAPTER 1/4" TUBE X 1/8"	1
23	1G0048	TUBING POLY 1/4 WHITE	1 ft
24	1G0046	TUBING POLY 1/4 RED	9 ft
25	1G0327	ELBOW 90 1/4 OD X 1/8 NPT	2
26	3G0082	PUSH BUTTON W/RED COVER – AIR INJECTION	1
27	1G0011	BRACKET JAR ASSEMBLY	1
28	1G0017	FILTER HOUSING ASSEMBLY	1

**Please order replacement parts from:**

**Getz Equipment Innovators**

**Pekin, IL 61554**

**Phone (888) 747-GETZ (4389)**

**Fax (309) 309-495-0625**

**[www.getzequipment.com](http://www.getzequipment.com)**

DRAWING 1

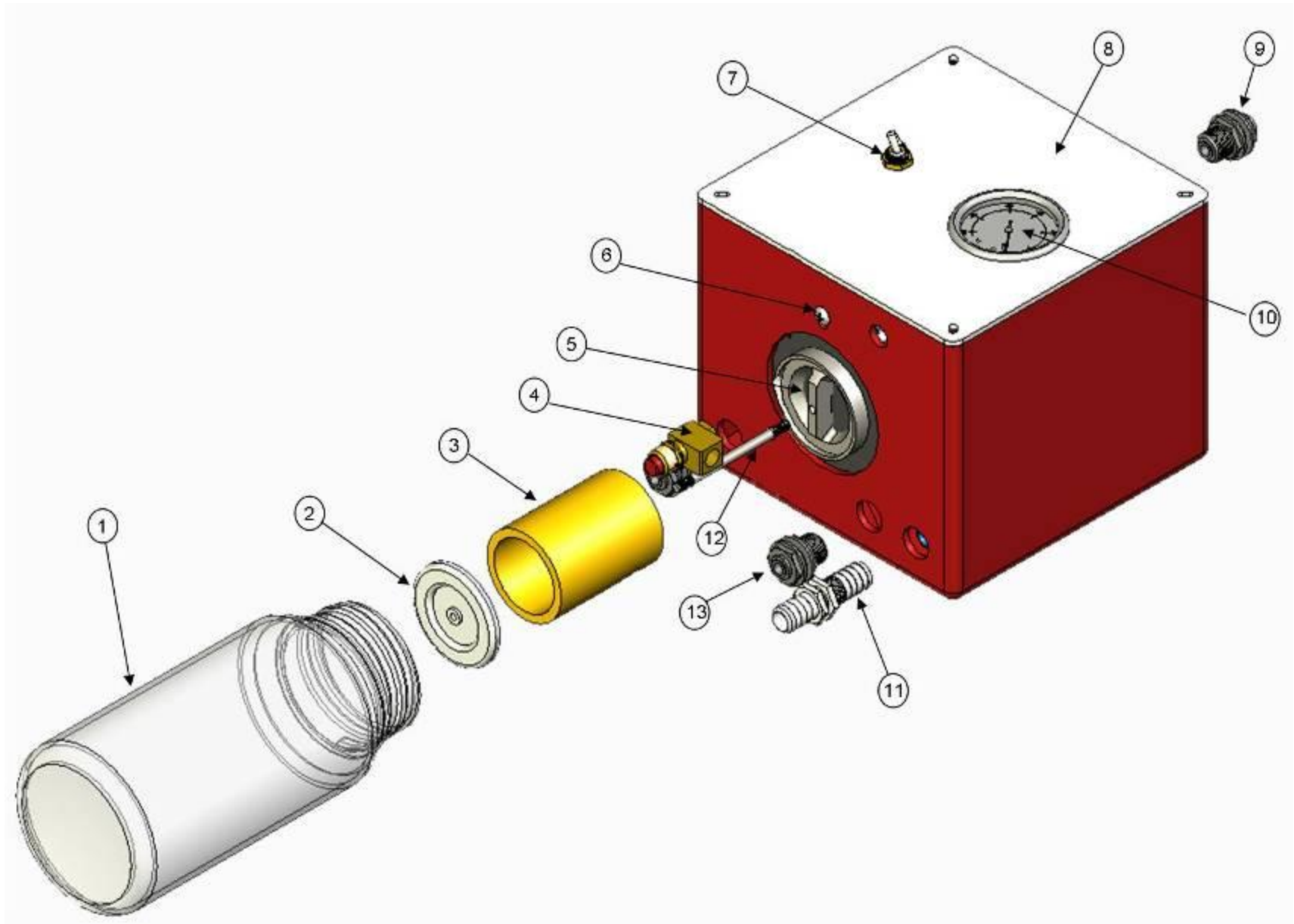

DRAWING 2 - Inside View

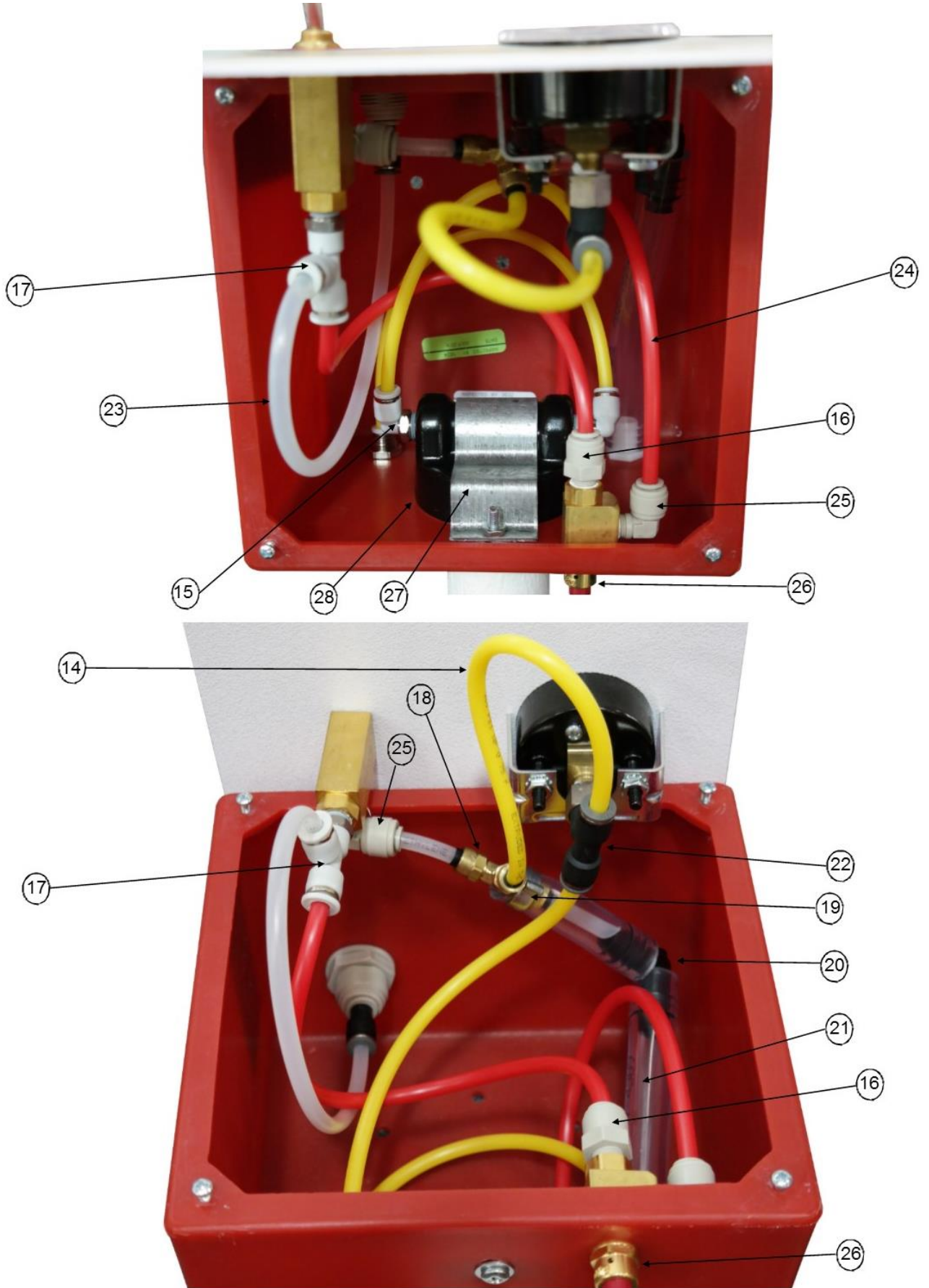

### DRAWING 3

ITEM NO.	PART NUMBER	DESCRIPTION
25	3G0058	DISHARGE LINE ½" 2000 PSI
26	1G0260	½" MALE SOCKET
27	1G0024	HOPPER FILTER
28	1G0034	LEVER LOCK RING FOR HOPPER
29	1G0048	VACUUM LINE - TUBING POLY 1/4 WHITE
30	3G0046	CONSOLE
31	1G0091	CONE FILL TUBE RUBBER
32	1G0032	FILL LINE - TUBING 1/2 I.D. CLEAR VINYL PER FT.
33	1G0020	JAR
34	1G0046	AIR INJECTION LINE - TUBING POLY 1/4 RED
35	N/A	HOPPER
36	1G0258	½" BALL VALVE - VENTED
37	N/A	PLASTIC STAND

**Please order replacement parts from:**

**Getz Equipment Innovators**

**Pekin, IL 61554**

**Phone (888) 747-GETZ (4389)**

**Fax (309) 495-0625**

**[www.getzequipment.com](http://www.getzequipment.com)**



# DRAWING 3



## Assembly Instructions

1. Remove Filling System from shipping container
2. Remove lid and filter by releasing the band assembly and inside you will find an assortment of hoses and the console.
3. Remove all items from inside the hopper.
4. Separate the red stand from the hopper.
5. If filling system is to be placed in a vehicle then it will need to be mounted to the floor using (4) 5/8 X 3" bolts (8) fender washers (top and underside of vehicle) and (4) nylon locking nuts (hardware not included). If it is for shop use then mounting the base to the floor is optional. When mounting make sure the vertical sight slot is in front. Leave at least a 4" clearance around the base from any wall or structure.
6. Attach the clear 1/2" vinyl tubing (line with black cone) to the 45 degree outlet at the base of the hopper; attach using provided worm gear clamp. Feed the clear vinyl tubing through the left front opening in the bottom of the stand.
7. Attach long end of the red 1/4" poly tubing to the air injection port on the right side of the hopper by pushing it firmly into the connector. Feed the short end of the red 1/4" poly tubing through the right rear opening at the bottom of the stand. Place the hopper back into stand with the logo and bulk head assembly in front.
8. Mount console to wall centering it above the filling system approximately 36" above the floor. Use the two mounting brackets on top of the console.
9. Attach the 6' clear 1/2" vinyl tubing to the vent line port on the base of the console on the right side by pushing it over the hose barb. It is best if the vent line goes through the floor of the vehicle or directed to an exhaust fan.
10. Attach red 1/4" poly tubing to the air injection port on the base of the console (right side) by pushing it firmly into the connector.
11. Mount ring bracket onto the wall next to the console approximately 46" from the floor.
12. Unscrew rubber cone from filler tube. Bring filler tube and 1/2" clear vinyl up through the bottom of the ring bracket. Screw rubber cone back onto filler tube.
13. Attach clear 1/4" poly tubing to the vacuum port on the base of the console (left side) by pushing it firmly into the connector.
14. Screw the discharge line (braided line with 1/2" ball valve) into the black bulkhead on the front of the hopper
15. Connect 3/8" white poly tubing to the fitting on the top of the console by pushing the air line into the fitting. Attach opposite end of 3/8" tubing to air compressor or regulator. Maximum incoming air should be no more than 80 psi.

## **Trouble Shooting for Fill System**

To determine if problem is in console, take the vacuum line (item #29) off of the elbow connector screwed into the filler tube. Turn the on-off switch (item # 7) on and put your finger over the vacuum line (item #29). Suction should be present and gauge should read a minimum 15" of vacuum. IF NOT, make sure jar gasket (item # 5) is in place and make sure jar is tight against gasket.

**DO NOT blow air through console or jar assembly.**

If there is suction at the end of the vacuum line (item #29), the trouble is NOT in the console. Most problems are commonly outside the console such as: lumpy chemical, moist chemical or a plugged fill hose.

**If the console is not working properly, it is recommended to replace the *venturi* (item # 18).**

1. Chemical will not flow when:
  - a. Extinguisher is not vacuum tight (i.e. a cartridge extinguisher with leaky cartridge receiver).
  - b. There is a kink in a hose.
  - c. The fill line and/or vacuum line are clogged.
  - d. Jar filter assembly on console is not properly sealed (must be tight).
  - e. Air supply is not regulated and maintained at 50 – 65 PSI
2. Overflow jars located under console should never be allowed to fill more than halfway before emptying.
  - a. Filter element in jars may be blown clean with an air gun (or similar tool) weekly.
  - b. Replace filter every six months.

## **Recommended Maintenance**

Getz Equipment Innovators has designed their plastic dry chemical fill systems to be the most maintenance-free available and to provide the longest equipment life. Nevertheless all equipment needs maintained and simple steps can be done to assure your fill system(s) continues to operate at optimum performance. To maintain optimum fill system performance we recommend the following maintenance items at a minimum. These recommendations are based on averages so frequencies may vary depending on number of extinguishers serviced using the dry chemical fill system(s).

### **Daily**

- Empty the plastic overflow jar when dry chemical reaches the line marked on the jar. Allowing the dry chemical to go above the line on the jar will allow chemical to flow back into the console tubing causing damage to the venturi, on/off valve, and vacuum gauge.

### **Weekly**

- Clean Hopper Lid Filter. Vacuum the inside of the filter. If there is dry chemical caked onto the filter it needs to be replaced.
  - Clean Jar Filter. Use only 10-15 psi to blow and clean the jar filter.
- Discharge Hose. Look for burn/soft spot at end by coupling and replace when worn

### **Annually (See Instructions Below)**

- Replace Hopper Lid Filter
- Replace Jar Filter
- Replace Jar Gasket
- Replace Venturi

# Maintenance Kit Instructions

## 100/150 lb Dry Chemical Fill Systems (Portables) Console 3G0089

### 1G0024 - Hopper Lid Filter (See Drawing #3)

1. Unlatch the hopper lever lock ring (35) and remove with the plastic hopper lid (34).
2. Remove old hopper lid filter (36) and discard.
3. Install new hopper lid filter and reinstall plastic hopper lid (beveled edge on top) and lever lock ring.

### 1G0067 – Jar Filter & 1G00205 – Jar Gasket (See Drawing #1)

4. Unscrew the Plastic Jar (1) counterclockwise from the bottom of the console and the metal Filter Cap (2). The Jar Filter (3) should be loose to remove after the metal Filter Cap is removed.
5. Remove the old Jar Gasket (5). Gently clean the Filter Housing Assembly (28) being careful not to blow air up into the Housing/Console that will force chemical into the tubing.
6. Install the new Jar Gasket and new Jar Filter with the metal Filter Cap. Install the Plastic Jar.

### 3G0151 – Venturi (See Drawing Below)

1. Remove the four corner screws on the front console lid to access the inside.
2. Remove vent line (5) from the poly elbow (6).
3. Use a 7/16” open end wrench to remove the two brass nuts at (1) and (2) and pull the clear and yellow ¼” tubing with those brass nuts from the venturi (4).
4. Unscrew (counterclockwise) the brass nut (3) using the ear clamp. This will leave the nut (3) in the vent tube (5) and the piece of ¼” clear plastic tube.
5. Remove the brass nut on the new venturi that has the piece of ¼” clear plastic tubing. The ¼” clear plastic tubing can be removed from the new venturi if the same tubing stayed in the vent tube (5).
6. Install the new venturi into the brass nut (3) that was left in the vent tube (5).
7. Remove the other two brass nuts in the new venturi.
8. Insert ¼” clear and yellow tubing and tighten brass nuts (1) and (2).
9. Insert vent line (5) into the poly elbow (6).
10. Replace front Console lid and tighten four corner screws.

