



GETZ EQUIPMENT INNOVATORS
PART NO.: 3G58616
MODEL: SV1 100 PR
VACUFILL SYSTEM
(Revised 2/25/14)



2320 Lakecrest Drive, Pekin IL 61554
PH. (888) 747-4389 • Fax (309) 495-0625
Website: www.getzequipment.com

LIMITED WARRANTY

Getz Equipment Innovators warrants its products, and component parts of any product manufactured by Getz Equipment Innovators, to be free from defects in material and workmanship for a period of twelve (12) months from the date of purchase. During the warranty period, any such defects will be repaired or the defective parts replaced **(at Getz Equipment Innovators' option)**. The warranty does not cover defects resulting from modification, alteration, misuse, exposure to corrosive conditions, extremely high temperatures, improper installation or maintenance. Warranties on component items not manufactured by Getz Equipment Innovators are provided by others whose warranty, evaluation and judgment will be final.

All implied warranties, including, but not limited to, warranties of fitness for purpose and merchantability, are limited to the time periods as stated above. In no event shall Getz Equipment Innovators be liable to incidental or consequential damages. Some states do not allow limitations on how long an implied warranty lasts or the exclusions or limitation of incidental or consequential damages, so that the above limitations or exclusions may not apply to you. Getz Equipment Innovators neither assumes nor authorizes any representative or other person to assume for it any obligation or liability other than as expressly set forth herein.

Mobile Service Vehicles:

The warranty does not cover:

- Defects in the chassis and or power unit
- Defects in separately manufactured products not produced by Getz Equipment Innovators
- Deterioration due to normal wear, tear, and exposure
- Repairs made necessary by negligent use, misuse, abuse, loading the service vehicle beyond its gross vehicle weight limitations, accident, acts of God, or other contingencies beyond the control of Getz Equipment Innovators.
- Repairs deemed necessary by reason of the failure to follow ordinary maintenance procedures.
- Repairs deemed necessary by reason of alterations done without Getz Equipment Innovators' written approval.

Warranty Service:

- All warranty repairs will be performed by Getz Equipment Innovators in Pekin, IL, unless otherwise authorized by Getz Equipment Innovators.

Freight:

- Getz Equipment Innovators will not be liable for shipping or transportation charges to or from customer's location.

This warranty gives you specific legal rights, and you may also have other rights which vary from state to state. To obtain performance to the obligation of the warranty, write to Getz Equipment Innovators, 2320 Lakecrest Drive, Pekin IL 61554, USA for instructions.

GETZ SV1-100-PR VACU-FILL SYSTEM

TABLE OF CONTENTS

PAGE #

1 GETZ SV1-100-PR VACU-FILL SYSTEM

2 PARTS LIST

3 DRAWING #1 - GENERAL ARRANGEMENT

4 DRAWING #2 - CONSOLE & FILTER ASSEMBLY

5 DRAWING #3 - CONSOLE LID INTERIOR

6 DRAWING #4 - CONSOLE BODY INTERIOR

7 ASSEMBLY INSTRUCTIONS

8 PROCEDURE FOR DISCHARGING FIRE EXTINGUISHER

9 PROCEDURE FOR FILLING FIRE EXTINGUISHER.

10-11 TROUBLE SHOOTING AND SERVICE AIDS

12 RECOMMENDED SPARE PARTS KIT

13 KIT HOSE SV1 LIST

14 KIT HOSE SV1 DRAWING #1

15 KIT HOSE SV1 DRAWING #2

GETZ SV1-100-PR VACU-FILL SYSTEM

MOTIVE POWER SOURCE

Air Compressor
Compressed Air
Nitrogen
CO2 Vapor

Customer must remove the syphon tube from the supply valve of the liquid CO2 tank to have vapor.

To get the maximum on your vacu-fill, the operation input pressure may range from 50 to 65 PSI to set your regulator for the best results, take the yellow vacuum line (#1C) out of connector (#34) on the bottom left outside console. Turn the on-off valve (#19) on and put your finger over the connector (#34). Then, adjust the regulator up or down, whichever is needed, so that you have maximum on your gauge.

CYCLE TIMES TO EXHAUST (OR EMPTY)

5 LB EXTINGUISHER (2.27 KG) = 15 SECONDS
10 LB EXTINGUISHER (4.50 KG) = 25 SECONDS
20 LB EXTINGUISHER (9.00 KG) = 30 SECONDS

CYCLE TIMES TO FILL

5 LB EXTINGUISHER (2.27 KG) = 20 SECONDS
10 LB EXTINGUISHER (4.50 KG) = 30 SECONDS
20 LB EXTINGUISHER (9.00 KG) = 60 SECONDS

SHIPPING SIZE OF CONTAINER AND WEIGHT

SV1-100-PR - 16" X 16" X 30" - 55 LBS

WARNING: MUST WEAR SAFETY GLASSES

PARTS LIST

<u>DRAWING #</u>	<u>PART #</u>	<u>DESCRIPTION</u>
1	3G58552	FILL LINE ASSEMBLY ABC
2	1G51221	FILLING CONE
3	3G58561	FTNG BR FILLER TUBE COMP
4	1G0047	MTL NYCOIL 1/4 YL
5	1G0032	MTL VINYL TUBE 1/2 CLR
6	3G58545	DCH ASY
7	1G51428	HUB MEYER 3/4 FMLE X FMLE
8	1G51686	PIPE RDCR BR 3/4 X 1/2
9	1G51789	SCREEN DCH
10	1G0077	PIPE ELB BR 1/2 X 1/2 ML
11	1G0084	VLV BALL BR 1/2 X 1/2 FMLE
12	1G0075	BARB HOSE BR 1/2 X 1/2
13	1G0041	CLAMP, OTEIKER 3/4
14	1G0033	MTL NYLON TUBE DCA 1 5/8
15	1G51109	BARB HOSE BR 1/2 X 1/4
16	1G0028	CPLG 1/4 FMLE STR THRU
17	1G0025	CPLG 1/4 X 1/8 ML STR
18	#####	BRACKET
19	3G58577	LID PWDR RECO
20	1G54040	FLTR FOR HOPPER LID
21	1G51469	LATCH HOPPER
22	1G0014	BKT RING
23	3G58539	CONSOLE SV1 COMPLETE
24	1G51484	LID SV1 CONSOLE
25	1G51148	BOX CONSOLE SV1
26	1G0207	STEM FILTER AC-396
27	1G0067	FLTR JAR
28	1G0206	CAP FLTR
29	1G51436	JAR PLASTIC VACU-FILL
30	1G51709	PIPE UNION PLAS 3/8 BLKHD
31	1G0049	MTL NYCOIL 3/8 WH
32	1G0116	CONN PLAS 1/4 ML X 3/8 TUBE
33	1G51285	DECAL LEXAN PANEL SV1
34	3G58649	VLV ON-OFF BR SV1
35	1G0120	PIPE ELB PLAS 1/4 ML X 1/4 TUBE
36	1G51590	NUT & FERRULE 1/4 PLAS
37	3G0151	VENTURI COMPLETE
38	1G51589	NUT & FERRULE 1/4 BR
39	1G0041	CLAMP OTEIKER 3/4
40	1G0099	PIPE ELB PLAS 1/2 w/BARB
41	1G0047	MTLNYCOIL 1/4 YL
42	1G51302	FASTNER LOCKING CONSOLE
43	1G0018	GAUGE 30 MG VACUUM
44	1G0200	PIPE TEE 1/4 X 1/8 FMLE BRANCH
45	1G0047	MTL NYCOIL 1/4 YL
46	1G0046	MTL NYCOIL 1/4 RD
47	1G51710	PIPE UNION RDCR PLAS 3/8 X 1/4
48	1G0049	MTL NYCOIL 3/8 WH
49	1G51233	CONN PLAS 1/4 FMLE X 1/4 TUBE
50	1G51124	BKT FLTR ASY JAR CLP
51	1G0017	FLTR ASY CASTING W/O JAR
52	1G51592	NUT & FERRULE 3/8 PLAS
53	1G51653	PIPE NIP BR 1/4 X 3 1/2
54	1G0205	GASKET JAR
55	3G59468	KIT HOSE SV1

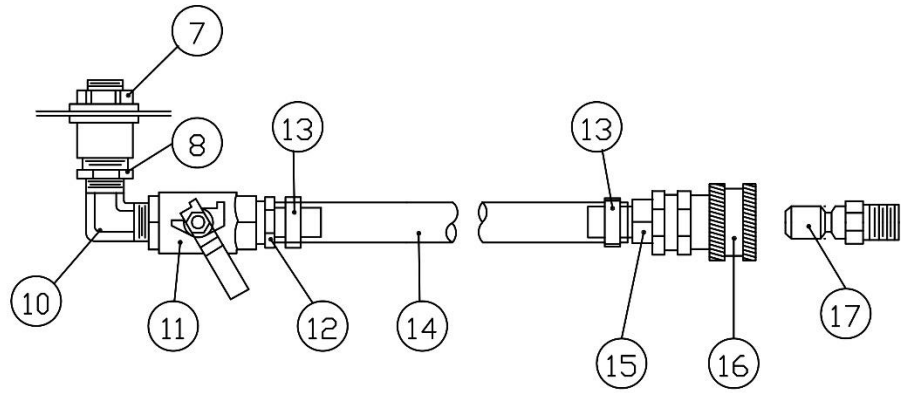
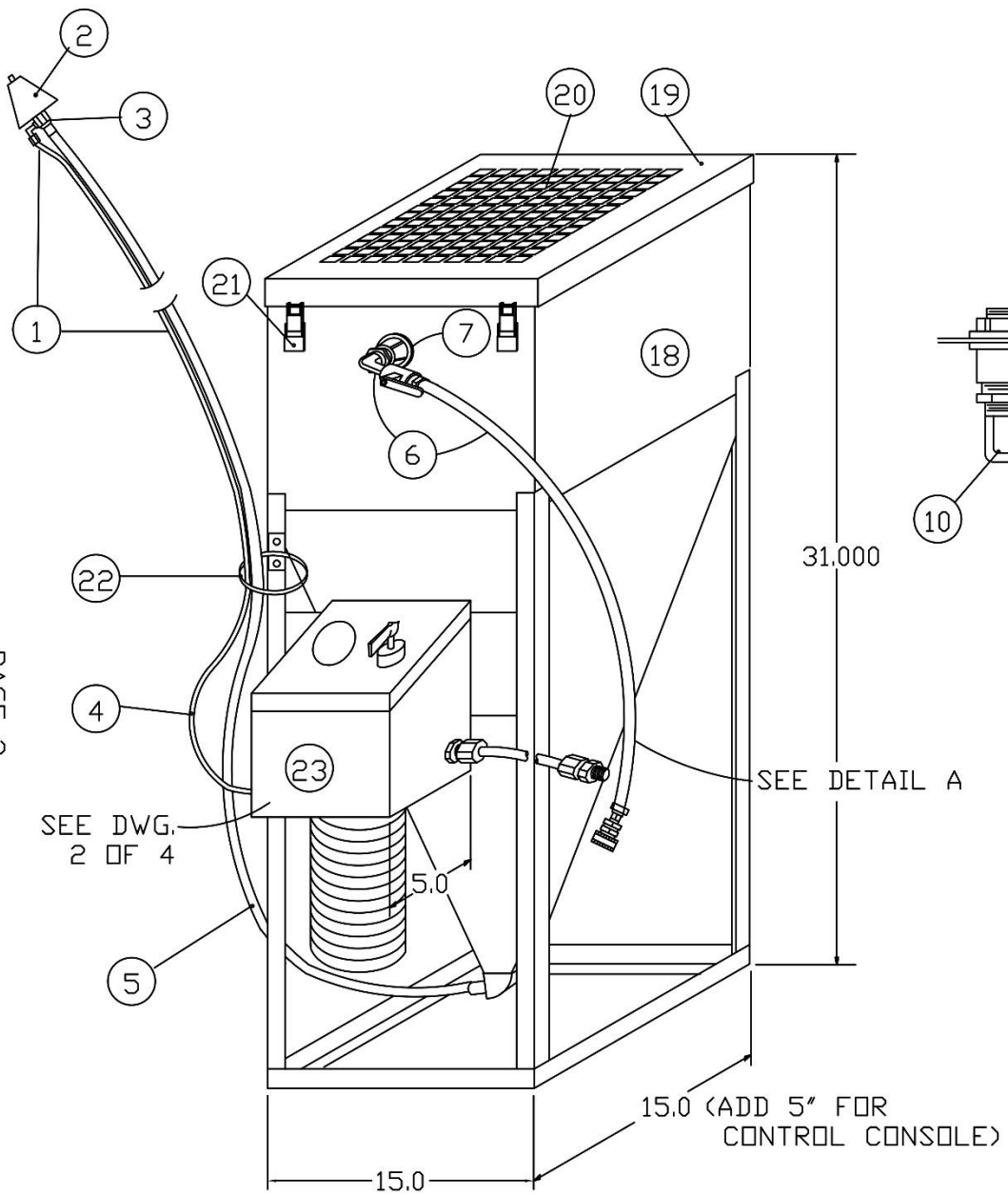

DETAIL A

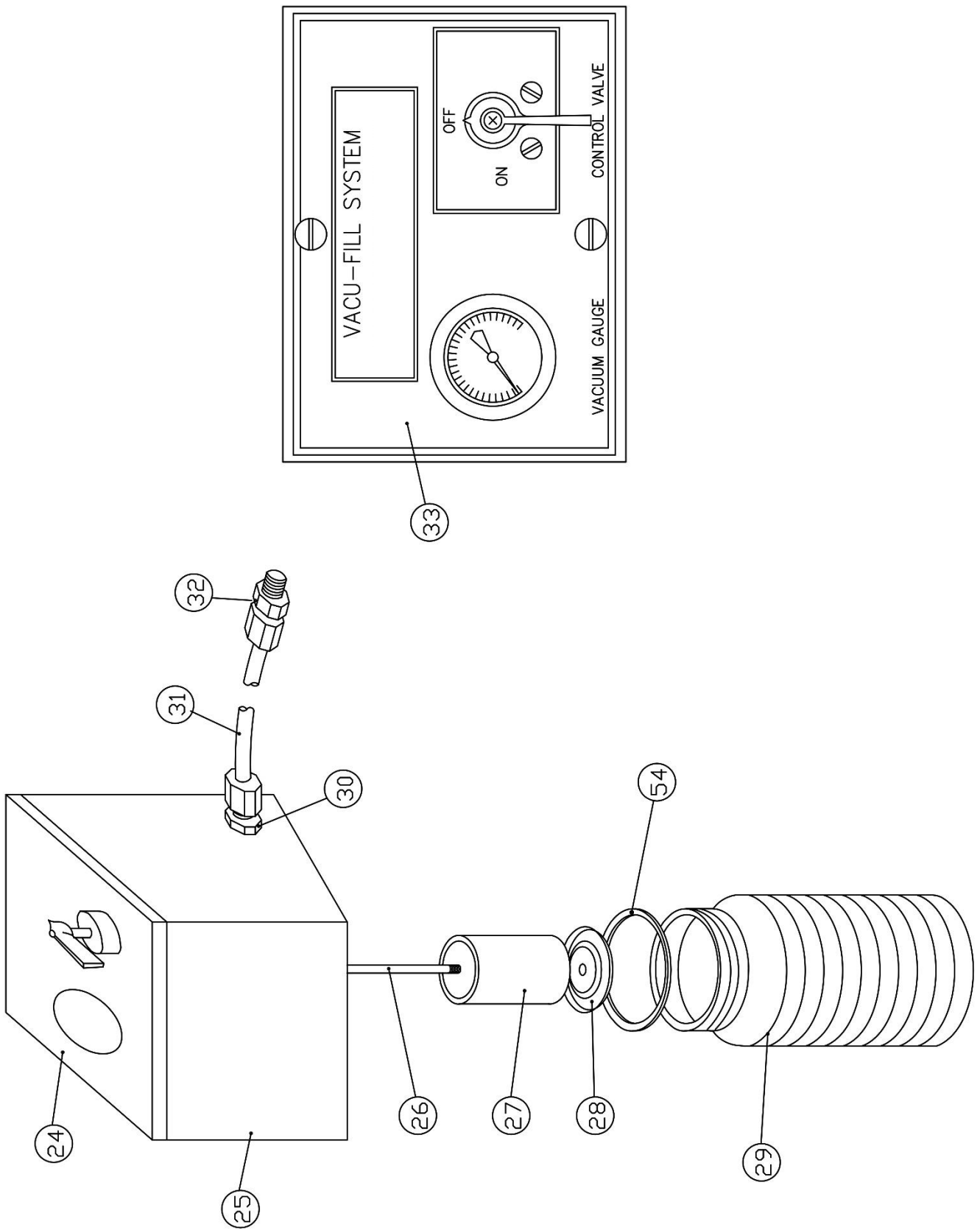

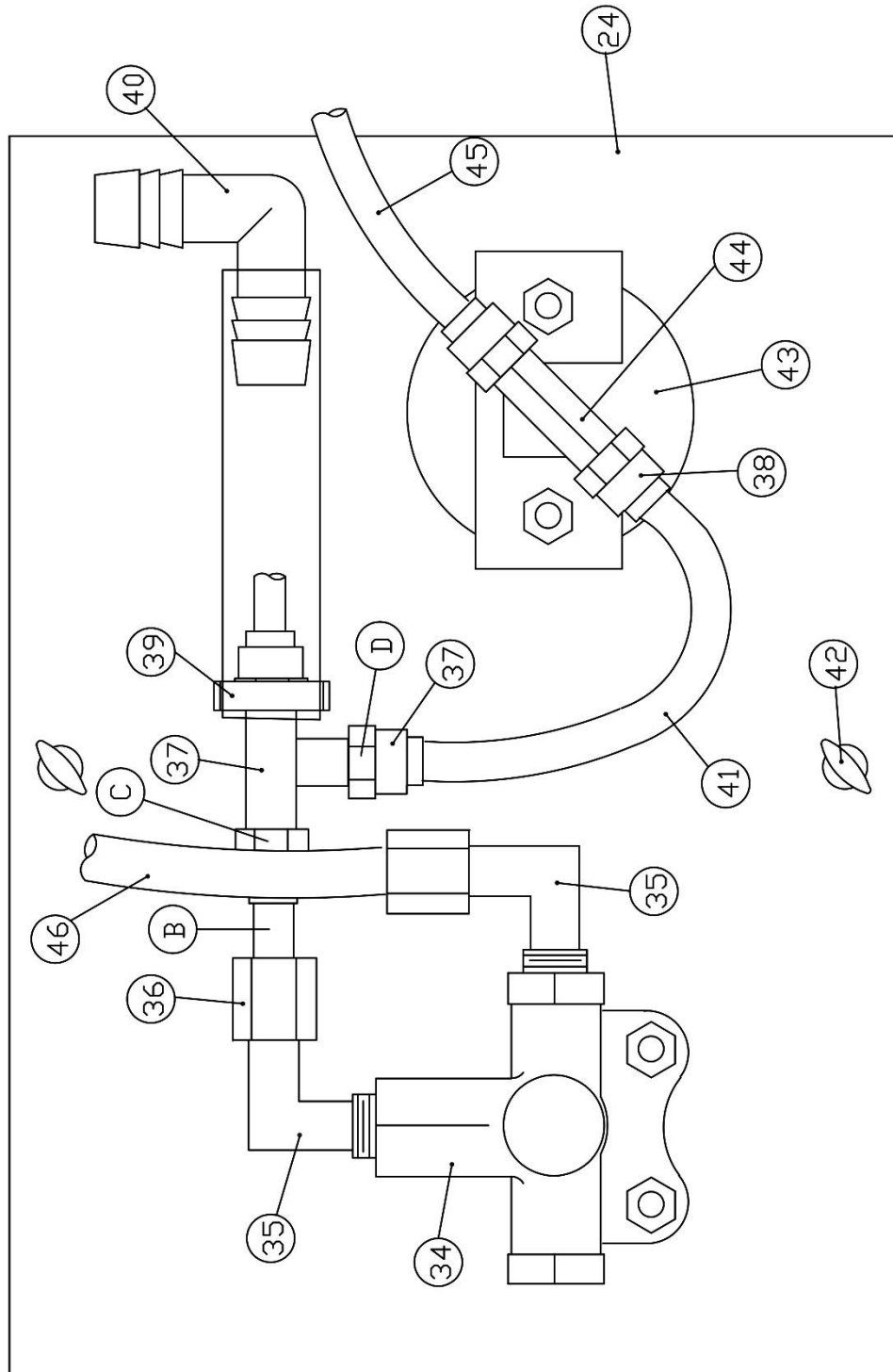

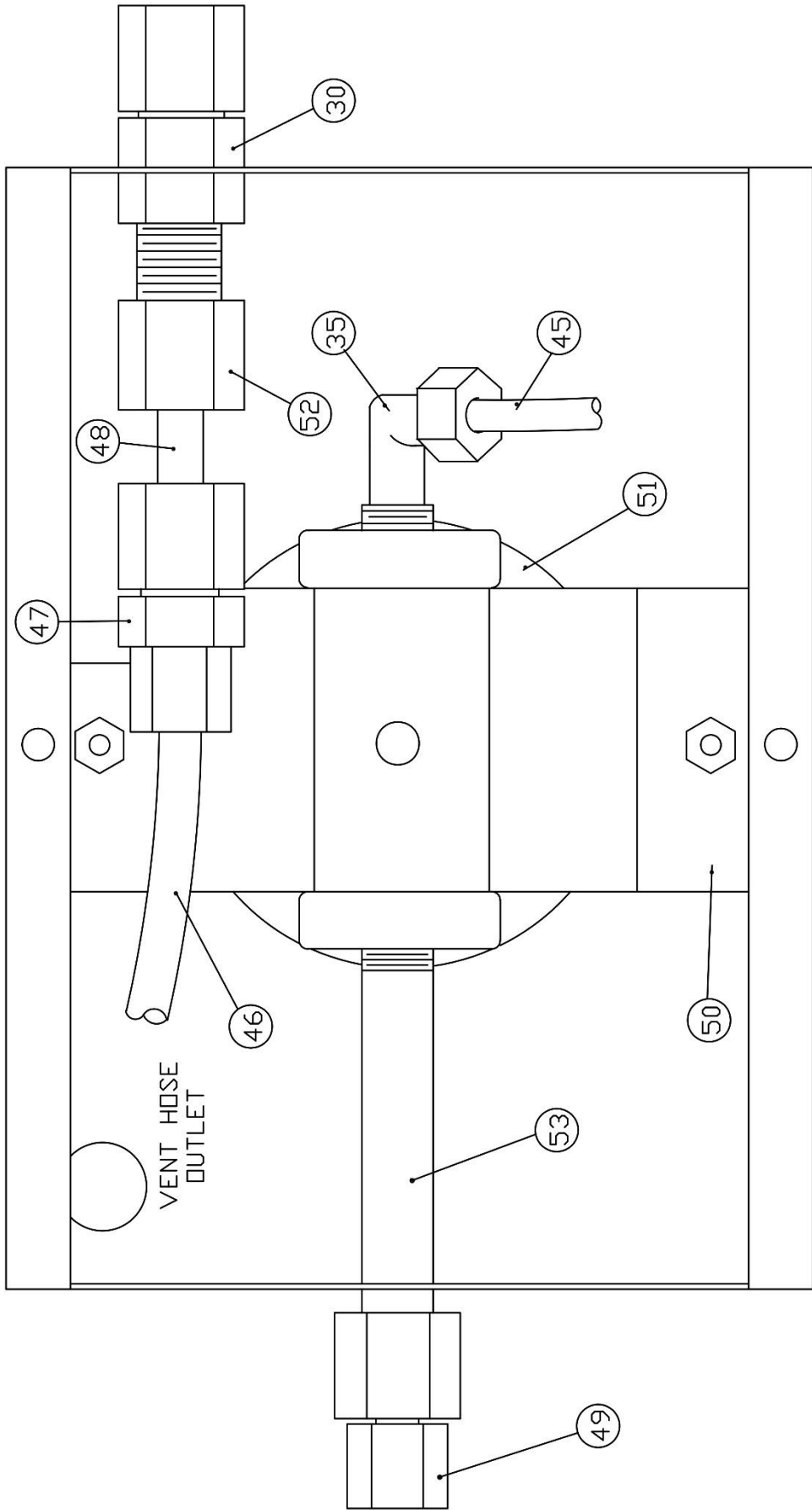

FRONT OF CONSOLE BODY

ASSEMBLY INSTRUCTIONS

1. Assembly unit per drawing #1 of 4 enclosed.
 - A) Install SV1 console (#8) slide the console clips on the bracket (#18), snapping the bolt heads into the holes of the bracket.
 - B) Install ring bracket (#22) into the two holes provided on front left side of hopper and stand.
* (**Bolts and nuts located in package in hopper.**)
 - C) Install the discharge assembly (#6) into the front top center 3/4" port, meyer hub (#7), provided on front of hopper.
 - D) Assemble hoses to console matching numbers on hoses to numbers at fitting on console.
 - E) Assemble 1/2" clear hose (#5) to the 45 degree hopper outlet on bottom of hopper.

Note: You will find it much easier to get the hose on bottom of hopper if you will preheat the end of hose in a cup of very hot water.
 - F) Attach the 6' piece of 1/2" tubing to the vent hose connection which is the black plastic nipple on the bottom of the console this is an air vent line.
 - G) Attach connector (#19) form right hand side of the console to your regulated air supply.

2. Adjust regulator for approximately 50 to 65 PSI and turn air pressure on. (**See page 1 for proper regulator setting.**) To operate unit, place aspirate cone in neck of fire extinguisher. Turn appropriate valve to "on" position. This will create vacuum in the extinguisher causing it to fill with chemical to proper weight predetermined by scale. If chemical flows into jar below console, cylinder has become full. At this time you must allow it to settle in cylinder if proper weight has not been reached. Tapping cylinder with a rubber hammer will speed up setting of chemical.

PORTABLE EXTINGUISHER DISCHARGE INSTRUCTIONS

1. Make sure the portable extinguisher is pressurized.
2. If portable extinguisher is not pressurized, and is full or partially full of chemical, hook up recharge adapter and pressurize to factory recommended pressure on gauge.
3. Connect proper discharge adapter with male quick coupler into valve assembly of extinguisher.
4. Connect discharge assembly (#6) to your discharge adapter on extinguisher.
5. Make sure that powder recovery lid is properly clamped to hopper.
6. Close valve (#11) and partially discharge extinguisher into the discharge hose (#14) to inspect chemical.
7. If chemical appears to be ok, you may open valve (#11) which will let the chemical enter the hopper and allow nitrogen pressure to escape through the powder recovery filter.
8. After pressure gauge is to zero, you may disconnect the discharge assembly hose and proceed to inspect or hydrotest the extinguisher.
9. Remove valve form extinguisher and cleaning:
 - A. Clean all powder out of threads of neck of extinguisher. **(Use a toothbrush).**
 - B. Clean interior of valve assembly and valve stem. **(This is very important to make sure extinguisher does not leak off).**
 - C. Clean thread on valve assembly and clean and lubricate O-ring.
 - D. Return valve and syphon tube assembly into neck on extinguisher. **(Hand tighten).**
 - E. Select the correct pressurizing adapter and place into discharge port.
 - F. Set regulator. Squeeze lever and pressurized to working pressure reading on gauge.
 - G. Once reaching proper pressure reading on gauge, release lever.
 - H. Disconnect recharge adapter and replace pull-pin for safety.
 - I. Check for leaks around neck O-ring and discharge port.
 - J. Follow up with returning hose assembly and tag to extinguisher.

FILLING EMPTY DRY CHEMICAL EXTINGUISHERS

1. Make sure scale is perfectly set and balanced to zero.
2. Make sure empty dry chemical extinguisher is visually checked on the inside for dryness and corrosion with inspection light.
3. Check label on empty extinguisher for type of chemical to be filled with.
4. The filling lines are also colored yellow and white, so you know yellow is ABC and white is BC chemical.
5. Set empty extinguisher on scale and check proper weight to be filled on extinguisher label.
6. Once proper chemical is determined, take yellow or white filling line and extend it to the top of the empty cylinder to be filled.
7. Take the rubber cone on the end of the filling line and place into top of cylinder neck with a 1/4 turn clockwise.
8. Scale: Two ways of weighing extinguisher for proper filling:
 - A) With extinguisher and filling line attached on scale, return scale back to zero and proceed to fill to recommended weight.
 - B) With extinguisher and filling line attached on scale, you can add recommended weight to the weight reading of extinguisher and fill line presently on scale.
9. Turn off-on valve to the “on” position until extinguisher reaches recommended weight. Then turn valve to “off” position once extinguisher is filled. **(If chemical returns to plastic jar before reaching proper weight, let chemical settle then turn valve back to “on” to get recommended weight).**
10. Remove filling line from neck of extinguisher to filling line ring bracket.

TROUBLE SHOOTING AND SERVICE AIDS

1. Chemical will not flow when:
 - A. Extinguisher is not vacuum tight. (i.e., **A cartridge extinguisher with a leaky cartridge receiver.**)
 - B. There is a kink in a hose.
 - C. The filling line and /or vacuum line is clogged.

Note: Never blow air pressure into the vacu-fill console or jar assembly. May cause injury or damage to the console
 - D. Jar filter assembly on console is not properly sealed. (**Jar must be screwed on tight.**)
 - E. Air supply is not regulated and maintained at 50 to 65 PSI.
2. Filter jars located under console should never be allowed to fill more than half way before emptying.
 - A. Filter element in jars may be blown clean with an air gun or similar device weekly. Replace jar filter every six months.
3. The on/off valve on the console may, after a period of time, tend to tighten up or become harder to operate.
 - A. First, shut off air pressure to console and bleed out all pressure in the system.
 - B. To dismantle valve (#19) simply loosen the nut or cap around the stem, (**counter clockwise**) and using the handle, turn to “on” position and pull entire stem, nut and bushing out of the valve body. Note the position of the key just behind the spring so you can reassemble valve correctly.
 - C. Using carburetor cleaner or similar cleaner, clean inner valve body and the bushing with two holes in it.
 - D. Put a thin film of lubriplate, or similar lubricant, on both parts.
 - E. Pull the small inner O-ring and the spring towards the handle and reassemble valve, mating key washer in the valve slot. (**The small O-ring seals and prevents leaks around stem.**)

SYSTEMATIC TROUBLE SHOOTING OF THE VACU-FILL SYSTEM

To determine if the problem is in the console, remove vacuum line (#4) from connector (#49) located in lower left side of console.

Now, with the vacuum line (#4) removed from the outside of console, place your finger over the fitting, (#49), on the outside of the console and turn on the valve. You should feel suction here, and the gauge should read over 15" of vacuum. If not, make sure jar gasket in (#51) is in place and make sure the jar is tight against gasket.

DO NOT BLOW AIR THROUGH CONSOLE OR JAR ASSEMBLY

JAR IS LIKELY TO EXPLODE IF SUBJECT TO MORE THAN 5 PSI

If you have suction at fitting (#49), you can be assured that the trouble is not in the console.

Most common problems outside the console are: lumpy chemical, moist chemical, and a plugged filling hose.

**** If the console is not working properly, we recommend replacing the venturi, (#37).**

PROCEDURE FOR CHANGING VENTURI VALVES ON VACU-FILL SYSTEM

1. Turn the two cover-locking screws a half turn and remove the cover so that inside of the console is exposed.
2. Using a 7/16" open end wrench, remove the nut (C) from the venturi.
3. Pull out plastic hose end (B).
4. Remove nut (D) and pull out the end of the plastic hose (#42).
5. Remove the old venturi (#37) by unscrewing it from the crimped clamp (#39).
6. Place the end of the new venturi in the crimped clamp (#39)
7. Replace hose end (#42), and tighten nut (D).
8. Replace hose end (B), and tighten nut (C).
9. Replace cover and tighten cover-locking screws.

RECOMMENDED MAINTENANCE KIT

Dear Customer:

Your recent purchase of our vacu-fill system will provide you with many years of dependable service.

Rest assured you have purchased the finest system available in today's marketplace. The advanced engineering and technological advancement employed in the development of this quality product has made it without equal, worldwide.

While this system is perhaps the most maintenance-free of any we manufacture, it must be remembered that anything man-made is capable of malfunctioning and may require simple repair.

For this reason, we have put together a maintenance kit which will eliminate the need for delay should your system ever fail. Chances are it won't. Yet, on occasion problems do arise for one reason or another. Call it an extra ounce of security.

I urge your consideration and modest investment in the following. Should you ever experience a problem, chances are you'll be equipped to repair it on the spot.

1 – 3G58900 - KIT SERV & MAINT SV1 & V1 VACU FL

Sincerely,

Getz Equipment Innovators

Note:

Do not modify any components within this system. Any use of parts other than Getz Equipment Innovators components excludes all written and implied liabilities.