



A DIVISION OF GETZ FIRE EQUIPMENT

**GETZ EQUIPMENT INNOVATORS  
PART NO.: 3G59613  
MODEL: SYS FILL SGL SV50 NEW  
50# OPTIMUM PERFORMANCE  
VACUFILL SYSTEM**



2320 Lakecrest Drive, Pekin IL 61554  
PH. (888) 747-4389 • Fax (309) 495-0625  
Website: [www.getzequipment.com](http://www.getzequipment.com)

## LIMITED WARRANTY

Getz Equipment Innovators warrants its products, and component parts of any product manufactured by Getz Equipment Innovators, to be free from defects in material and workmanship for a period of twelve (12) months from the date of purchase. During the warranty period, any such defects will be repaired or the defective parts replaced **(at Getz Equipment Innovators' option)**. The warranty does not cover defects resulting from modification, alteration, misuse, exposure to corrosive conditions, extremely high temperatures, improper installation or maintenance. Warranties on component items not manufactured by Getz Equipment Innovators are provided by others whose warranty, evaluation and judgment will be final.

All implied warranties, including, but not limited to, warranties of fitness for purpose and merchantability, are limited to the time periods as stated above. In no event shall Getz Equipment Innovators be liable to incidental or consequential damages. Some states do not allow limitations on how long an implied warranty lasts or the exclusions or limitation of incidental or consequential damages, so that the above limitations or exclusions may not apply to you. Getz Equipment Innovators neither assumes nor authorizes any representative or other person to assume for it any obligation or liability other than as expressly set forth herein.

### **Mobile Service Vehicles:**

The warranty does not cover:

- Defects in the chassis and or power unit
- Defects in separately manufactured products not produced by Getz Equipment Innovators
- Deterioration due to normal wear, tear, and exposure
- Repairs made necessary by negligent use, misuse, abuse, loading the service vehicle beyond its gross vehicle weight limitations, accident, acts of God, or other contingencies beyond the control of Getz Equipment Innovators.
- Repairs deemed necessary by reason of the failure to follow ordinary maintenance procedures.
- Repairs deemed necessary by reason of alterations done without Getz Equipment Innovators' written approval.

Warranty Service:

- All warranty repairs will be performed by Getz Equipment Innovators in Pekin, IL, unless otherwise authorized by Getz Equipment Innovators.

Freight:

- Getz Equipment Innovators will not be liable for shipping or transportation charges to or from customer's location.

This warranty gives you specific legal rights, and you may also have other rights which vary from state to state. To obtain performance to the obligation of the warranty, write to Amerex Corp dba Getz Equipment Innovators, 2320 Lakecrest Drive, Pekin IL 61554, USA for instructions.

# **!!WARNING!!**

**SEVERE DAMAGE AND/OR INJURY MAY RESULT**

## **50 & 100 # CAPACITY VACUFILLS:**

*DO NOT* DISCHARGE ANY EXTINGUISHER CYLINDER EXCEEDING 195 PSI AND NOT EXCEEDING 30 POUNDS IN AGENT WEIGHT.

## **150 # CAPACITY VACUFILLS:**

*DO NOT* DISCHARGE ANY EXTINGUISHER CYLINDER EXCEEDING 195 PSI WITHOUT THE USE OF GETZ EQUIPMENT INNOVATORS P/N 59745, WHEELED SYSTEM DISCHARGE ASSEMBLY, INSTALLED.

FAILURE TO INSTALL AND OPERATE EQUIPMENT ACCORDING TO THE GUIDELINES PUT FORTH IN THE INSTRUCTION MANUAL SHALL VOID WARRANTY.

# **GETZ SGL SV 50 PR VACU-FILL SYSTEM**

## **TABLE OF CONTENTS**

### **PAGE #**

1 .....	GETZ SGL SV 50 PR VACU-FILL SYSTEM
2 .....	PARTS LIST
3 .....	DRAWING #1 - GENERAL ARRANGEMENT
4 .....	DRAWING #2 - DISCHARGE ASSEMBLY DETAIL
5 .....	DRAWING #3 - CONSOLE AND FILTER ASSEMBLY
6 .....	DRAWING #4 - CONSOLE LID INTERIOR
7 .....	DRAWING #5 - CONSOLE BODY INTERIOR
8 .....	ASSEMBLY INSTRUCTIONS
9 .....	PROCEDURE FOR DISCHARGING FIRE EXT.
10 .....	PROCEDURE FOR FILLING FIRE EXT.
11 .....	TROUBLE SHOOTING & SERVICE AIDS
12 .....	TROUBLE SHOOTING & SERVICE AIDS - CONT.
13 .....	RECOMMENDED MAINTENANCE KIT

## **GETZ SGL SV 50 PR VACU-FILL SYSTEM**

### **MOTIVE POWER SOURCE**

AIR COMPRESSOR  
COMPRESSED AIR  
NITROGEN  
CO2 VAPOR

**Customer must remove the siphon tube from the supply valve of the liquid CO2 tank to have vapor.**

To get the maximum performance from your Vacu-fill, the operating input pressure may range from 40 to 50 PSI. To set your regulator for best results, take the white vacuum line (#5) out of connector (#35) on the bottom left outside console. Turn the on-off valve (#19) to the "ON" position and put your finger over connector (#35). Then, adjust regulator up or down, whichever is needed, so that you have the maximum on your gauge.

### **CYCLE TIMES TO EXHAUST (OR EMPTY)**

5 LB EXTINGUISHER (2.27 KG) = 15 SECONDS  
10 LB EXTINGUISHER (4.50 KG) = 25 SECONDS  
20 LB EXTINGUISHER (9.00 KG) = 30 SECONDS

### **CYCLE TIMES TO FILL**

5 LB EXTINGUISHER (2.27 KG) = 10 SECONDS  
10 LB EXTINGUISHER (4.50 KG) = 15 SECONDS  
20 LB EXTINGUISHER (9.00 KG) = 30 SECONDS

### **SHIPPING SIZE OF CONTAINER**

SGL SV 50 PR - 13" X 13" X 25 1/4"

**WARNING: MUST WEAR SAFETY GLASSES**

## PARTS LIST

<u>DRAWING #</u>	<u>PART #</u>	<u>DESCRIPTION</u>
1	3G58838	POWDER RECOVERY LID 50#
2	XXXX	BRACKET
3	3G58545	DCH ASY V-50 PR
4	1G0049	MTL NYCOIL 3/8" WH
5	1G0048	MTL NYCOIL 1/4 WH X 7'
6	1G0032	MTL VINYL TUBE 1/2 CLR X 9'
7	1G51221	CONE FILL
8	3G59603	SV1 CONSOLE COMPLETE
9	1G51484	LID SV1 CONSOLE
10	1G51148	BOX CONSOLE SV1
11	1G0207	STEM FILTER AC-396
12	1G0067	FLTR WH JAR ASSY
13	1G0206	CAP FLTR
14	1G51436	JAR PLASTIC VACU-FILL
15	1G51709	PIPE UNION PLAS 3/8 BLKHD
16	1G0101	CLAMP PLAS HOPPER OUTLET
17	1G0116	CONN PLAS 1/4
18	1G51285	DECAL LEXAN PANEL SV1
19	3G58649	VALVE ON-OFF BR SV1
20	1G0120	PIPE ELB PLAS 1/4ML X 1/4TUBE
21	1G51590	NUT & FERRULE 1/4 PLAS
22	1G54206	PIPE ELB PLAS 1/4 FMLE X 1/2 BARB
23	1G0327	PIPE ELB PLAS 1/8 ML X 1/4 TUBE
24	1G51695	PIPE TEE BR 1/4 BOX
25	1G54039	FLTR LID SLIP-OVER 50# HOPPER
26	1G0099	PIPE ELB PLAS w/BARB
27	1G51680	PIPE RDCR BELL 1/4 X 1/8
28	1G51302	FASTENER LOCKING CONSOLE
29	1G0018	GAUGE 30MG VACUUM
30	1G54400	VENTURI NEW 2 <sup>nd</sup> GENERATION
31	1G51710	PIPE UNION RDCR PLAS 3/8 X 1/4
32	1G0049	MTL NYCOIL 3/8 WH
33	1G51233	CONNECTOR PLAS 1/4FML X 1/4TUB
34	1G0011	BKT FLTR ASY JAR CLP
35	1G0017	FLTR ASY CASTING W/O JAR
36	1G51592	NUT & FERRULE 3/8 PLAS
37	1G51653	PIPE NIP BR 1/4 X 3 1/2
38	1G0205	GASKET JAR
39	1G51789	SCREEN DCH
40	1G51428	HUB MEYER 3/4 FMLE X FMLE
41	1G0308	PIPE RDCR BR 3/4X1/4
42	1G51624	PIPE ELB BR 1/4 ST
43	1G0042	VLV BALL 1/4 X 1/4 ML
44	1G0075	BARB HOSE BR 1/2 X 1/2
45	1G0033	MTL NYLON TUBE DCA1 5/8 - 24"
46	1G51109	BARB HOSE BR 1/2 X 1/4
47	1G0028	CPLG 1/4 FMLE STR THRU
49	3G58561	FTNG BR FILLER TUBE COMP
50	1G51469	LATCH HOPPER
51	1G0159	CLAMP BROOM
52	1G0014	BRKT RING
53	1G0591	ELBOW STREET 3/4 90 DEGREE

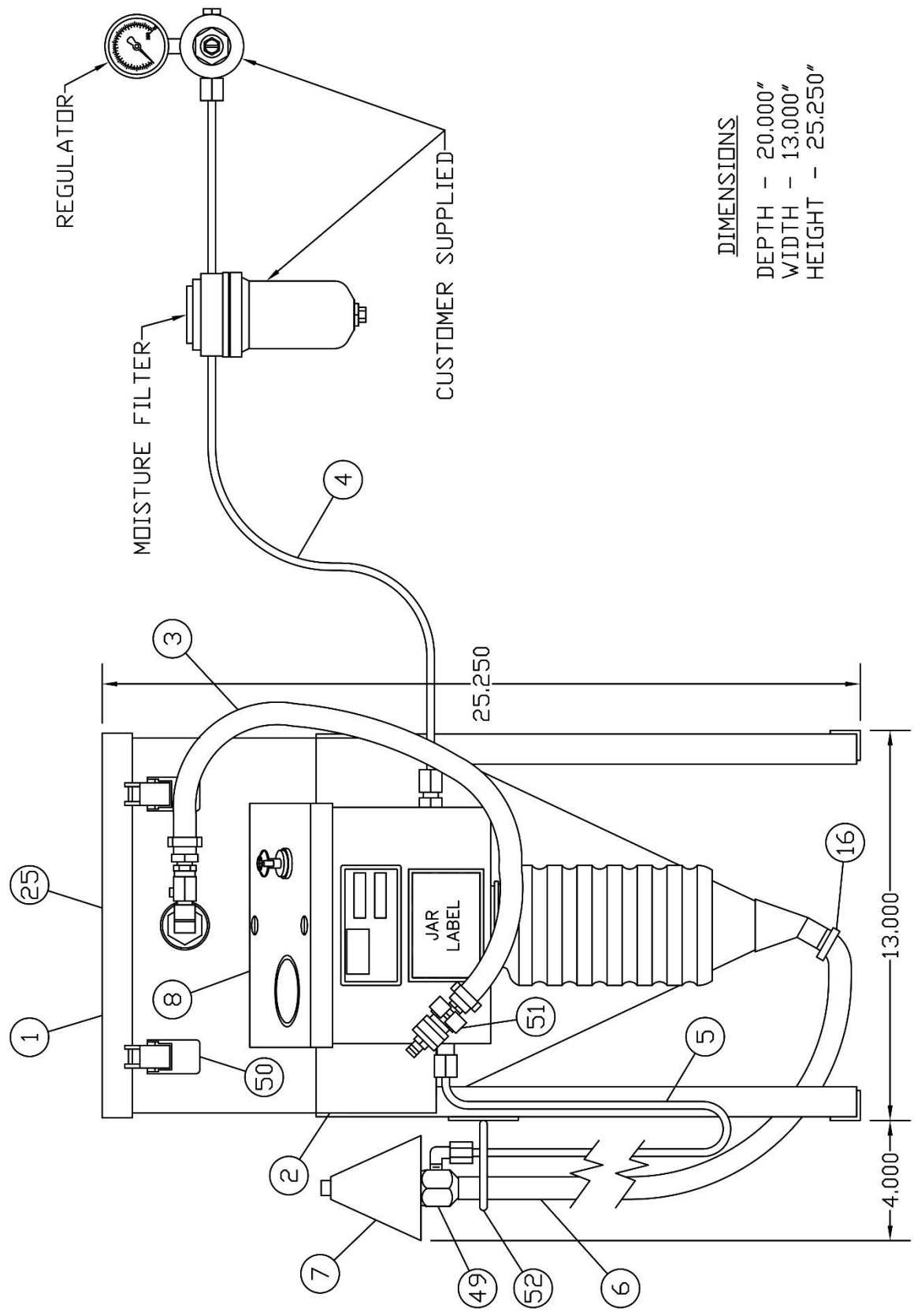

DIMENSIONS  
 DEPTH - 20.000"  
 WIDTH - 13.000"  
 HEIGHT - 25.250"

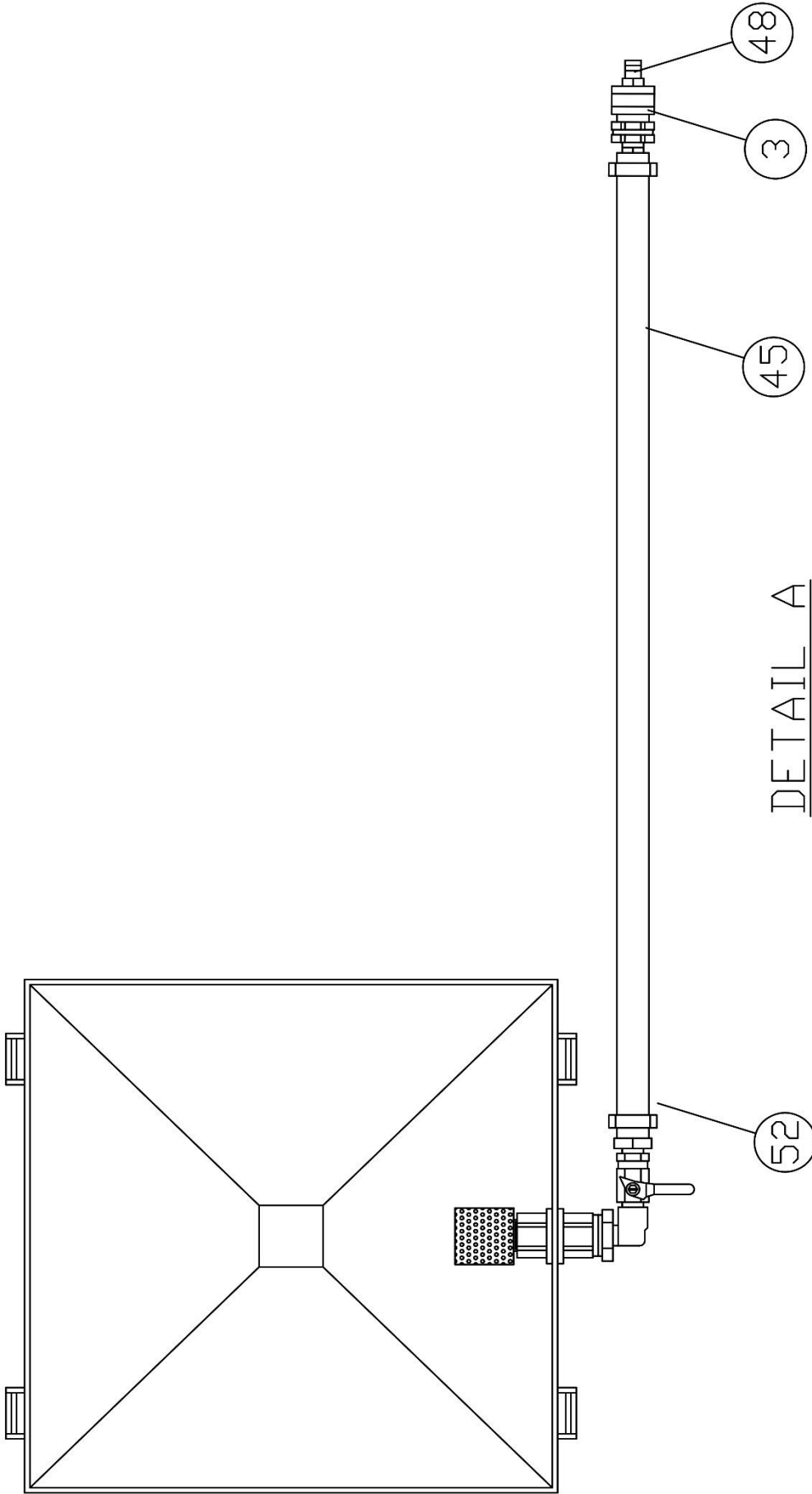

NOTE:

IF PART #67 (NYLON REINFORCED HOSE) BECOMES DISCOLORED,  
 IT MUST BE REPLACED SO OPERATOR CAN VISUALLY INSPECT  
 CHEMICAL.

REPLACEMENT PART #1G0033



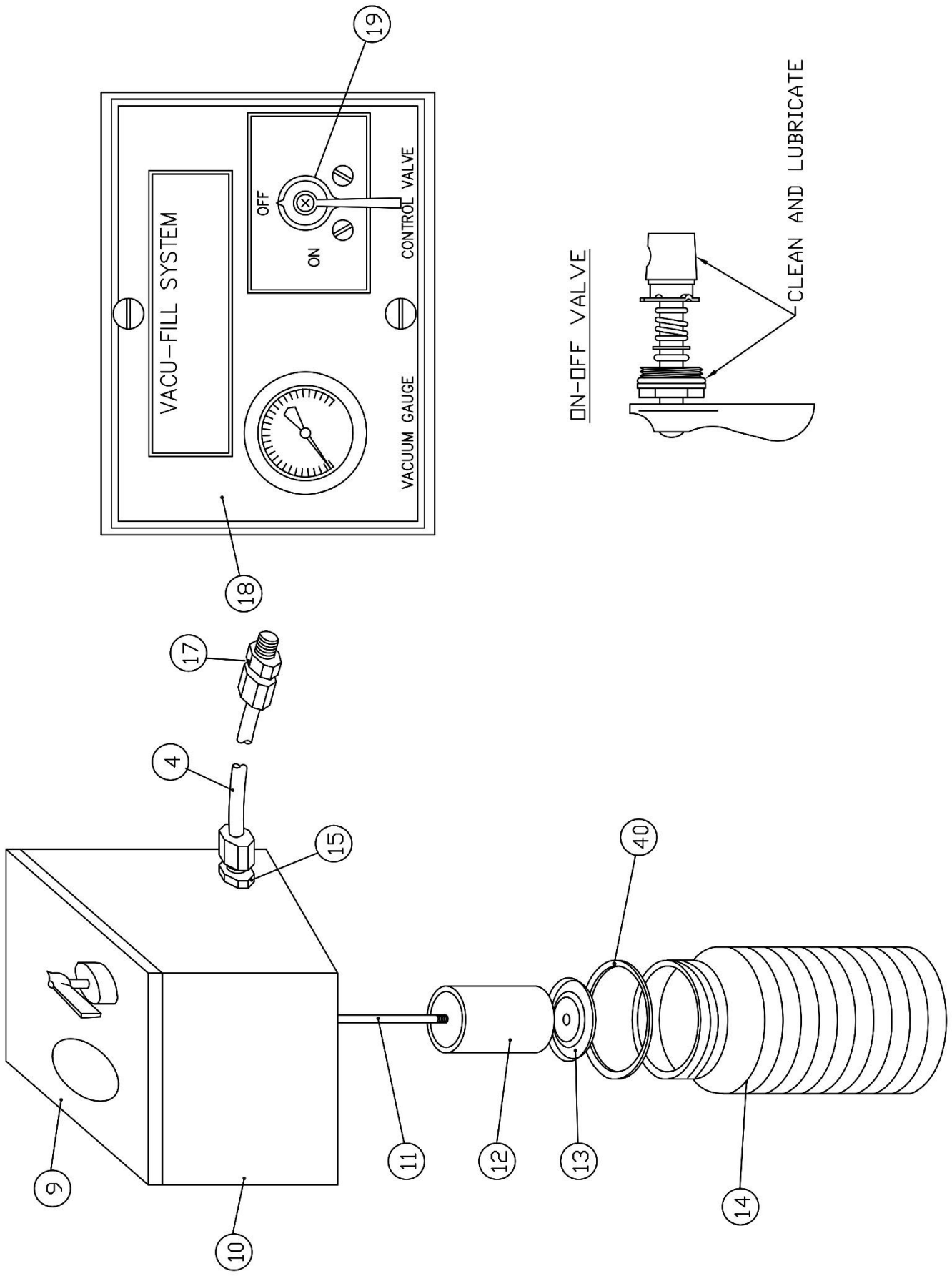

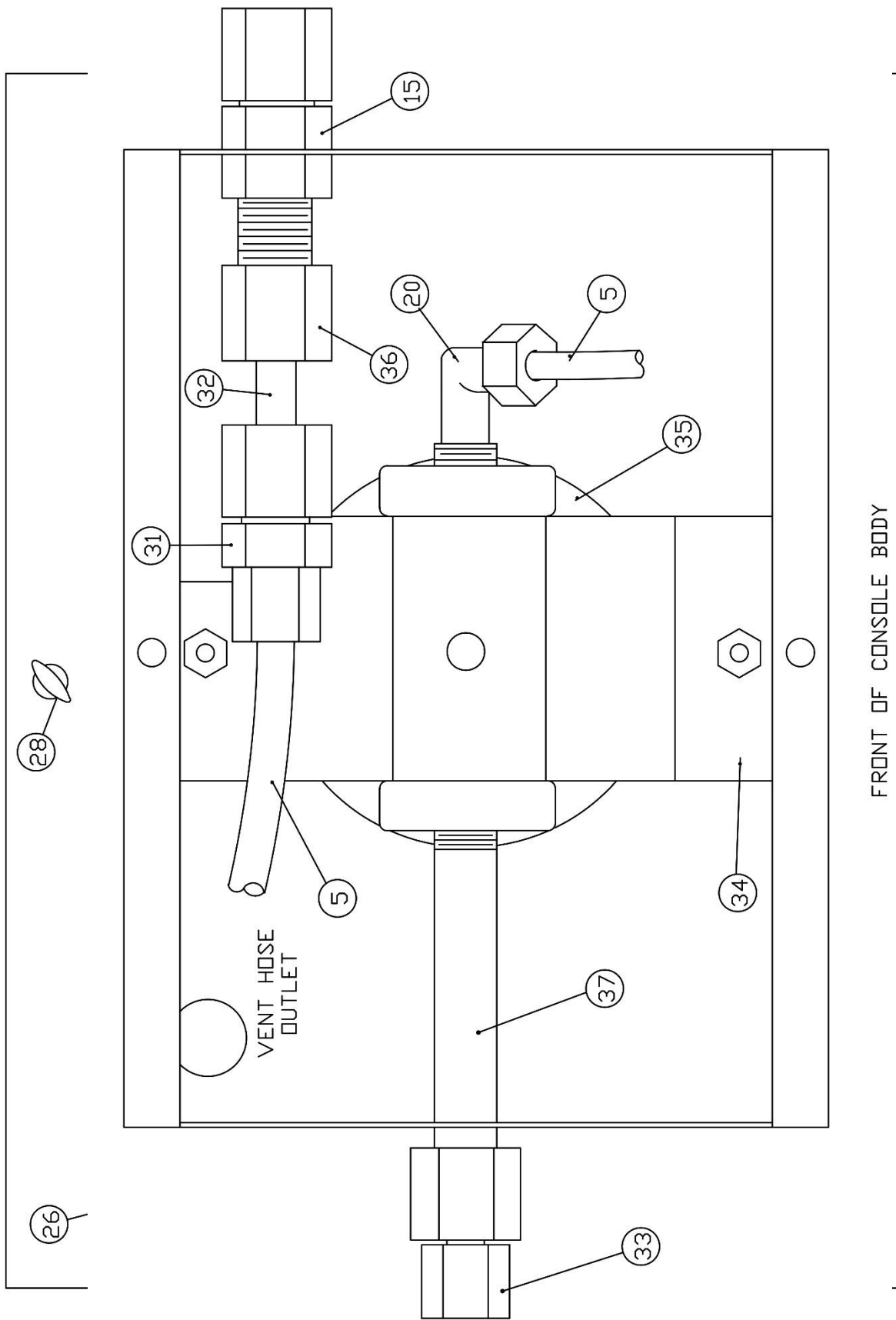

## ASSEMBLY INSTRUCTIONS

1. Assembly unit per drawings #1 of 4 enclosed.

A) Install SV1 console (#8) slide the console clips on the bracket (#2), snapping the bolt heads into the holes of the bracket.

B) Install ring bracket (#54) in the two holes provided on the front left side of hopper and stand.

\*\* (Bolts and nuts are located in a package in the hopper.)

C) Install the discharge assembly (#3) into the front top center 3/4" port, meyer hub (#42), provided on the front of hopper.

D) Assemble hoses to console matching numbers on hoses to numbers at fittings on console.

E) Assemble 1/2" clear hose (#6) to the 45 degree hopper outlet on bottom of hopper.

Note: You will find it much easier to get the hose on the bottom of hopper if you preheat the end of the hose in a cup of very hot water.

F) Attach the 6' piece of 1/2" tubing to the vent hose connection which is the black plastic nipple on the bottom of the console this is an air vent line.

G) Attach connector (#17) from right hand side of the console to your regulated air supply. (Approximately 65 PSI)

H) Then screw the plastic jar to the bottom of the console box over the filter.

2. Apply pressure to the console and adjust your regulator for approximately 50 to 80 PSI. (See page 1 for proper regulator setting.)

## PORTABLE EXTINGUISHER DISCHARGE INSTRUCTIONS

- 1) Make sure the portable extinguisher is pressurized.
- 2) If portable extinguisher is not pressurized, and is full or partially full of chemical, discharge the contents of the extinguisher into the hopper system and pour out or vacuum the remaining chemical from the extinguisher.
- 3) Connect proper discharge adapter with male quick coupler (#50) into valve assembly of extinguisher.
- 4) Connect discharge assembly hose (#3) to the discharge adapter (#50) on extinguisher.
- 5) Make sure the powder recovery lid is properly clamped to hopper.
- 6) Close valve (#45) and partially discharge extinguisher into the discharge hose (#47) to inspect chemical.
- 7) If chemical appears to be OK, you may open valve (#45) which will let the chemical enter the hopper and allow nitrogen pressure to escape through the powder recovery filter.
- 8) After the extinguisher's pressure gauge has reached zero, you may disconnect the discharge assembly hose (#3) and proceed to inspect or hydrotest the extinguisher.
- 9) Remove valve from extinguisher and cleaning:
  - A. Clean all powder out of threads of neck of extinguisher. (Use a toothbrush).
  - B. Clean interior of valve assembly and valve stem. (This very important to make sure extinguisher does not leak off).
  - C. Clean threads on valve assembly and clean and lubricate o-ring.
  - D. Refill the extinguisher with chemical. (See page 10).

## **FILLING EMPTY DRY CHEMICAL EXTINGUISHERS**

- 1) Make sure scale is perfectly set and balanced to zero.
- 2) Make sure empty dry chemical extinguisher is visually checked on the inside for dryness and corrosion with inspection light.
- 3) Check label on empty extinguisher for type of chemical to be filled with.
- 4) The filling lines are also colored yellow and white, so you know yellow is ABC and white is BC chemical.
- 5) Set empty extinguisher on scale and check proper weight to be filled on extinguisher label.
- 6) Once proper chemical is determined, take yellow or white filling line and extend it to the top of the empty cylinder to be filled.
- 7) Take the rubber cone (#7) on the end of the filling line (#6) and place into top of cylinder neck with a 1/4 turn clockwise.
- 8) Scale: Two ways weighing extinguisher for proper filling:
  - A) With extinguisher and filling line attached on scale, return scale back to zero and proceed to fill to recommended weight.
  - B) With extinguisher and filling line attached on scale, you can add recommended weight to the weight reading of extinguisher and fill line presently on scale.
- 9) Turn on-off valve (#19) to the "ON" position until extinguisher reaches recommended weight. Then turn valve to "OFF" position once extinguisher is filled. (If chemical returns to plastic jar before reaching proper weight, let chemical settle then turn valve back to "ON" to get recommended weight).
- 10) Remove filling line cone (#7) from neck of extinguisher to filling line ring bracket.

## TROUBLE SHOOTING AND SERVICE AIDS

- 1) Chemical will not flow when:
  - A. Extinguisher is not vacuum tight. (i.e., a cartridge extinguisher with a leaky cartridge receiver.)
  - B. There is a kink in a hose.
  - C. The filling line and/or vacuum line are clogged.

Note: Never blow air pressure into the Vacu-Fill console or jar assembly. May cause injury or damage to the console.

  - D. Jar filter assembly on console is not properly sealed. (Jar must be screwed on tight.)
  - E. Air supply is not regulated and maintained at 50 to 80 PSI.
- 2) Filter jars located under console should never be allowed to fill more than half way before emptying.
  - A. Filter element in jars may be blown clean with an air gun or similar device weekly. Replace filter twice a year.
- 3) The on/off valve (#19) on the console may, after a period of time, tend to tighten up or become harder to operate
  - A. First thing shut off air pressure to console and bleed out all pressure in the system.
  - B. To dismantle valve (#19), simply loosen the nut or cap around the stem, (counter-clockwise) and using the handle, turn to "ON" position and pull entire stem, nut and bushing out of the valve body. Note the position of the key just behind the spring so you can reassemble valve correctly.

(See Page 5)

Using carburetor cleaner or similar cleaner, clean inner valve body and the bushing with three holes in it.

Put a thin film of lubriplate, or similar lubricant, on both parts.

Pull the small inner "O" ring and the spring towards the handle and reassemble valve, mating key washer in the valve slot. (The small o-ring seals and prevents leaks around stem.)
- 4) At the end of the day we recommend that you do a dry air run. First, remove the jar and filter, then turn on the console for 30 seconds. Turn off the console and then reinstall filter and jar.

## TROUBLE SHOOTING AND SERVICE AIDS

(CONTINUED)

To determine if the problem is in the console, remove vacuum line (#5) from conector (#35) located on lower left side console.

Now, with the vacuum line (#5) removed from the outside of console, place your finger over the fitting, (#35), on the outside of the console and turn on the valve. You should feel suction here, and the gauge should read over 15" of vacuum. If no, make sure jar gasket in (#37) is in place and make sure the jar is tight against gasket.

DO NOT BLOW AIR THROUGH CONSOLE OR JAR ASSEMBLY

JAR IS LIKELY TO EXPLODE IF SUBJECT TO MORE THAN 5 PSI

If you have suction at fitting (#35), you can be assured that the trouble is not in the console.

Most common problems outside the console are: lumpy chemical, moist chemical, and a plugged filling hose.

## **RECOMMENDED MAINTENANCE KIT**

Dear Customer:

Your recent purchase of our Vacu-Fill system will provide you with many years of dependable service.

Rest assured you have purchased the finest system available in today's marketplace. The advanced engineering and technological advancement employed in the development of this quality product has made it without equal, worldwide.

While this system is perhaps the most maintenance-free of any we manufacture, it must be remembered that anything man-made is capable of malfunctioning and may require simple repair.

For this reason, we have put together a maintenance kit which eliminate the need for delay should your system ever fail. Changes are it won't. yet, on occasion problems do arise for one reason or another. Call it an extra ounce of security.

I urge your consideration and modest investment in the following. Should you ever experience a problem, chances are you'll be equipped to repair it on the spot.

1 - 3G59637 - KIT SERV & MAINT SV 50 NEW

Sincerely,

Amerex Corp dba Getz Equipment Innovators

Note:

Do not modify any component within this system. Any use of parts other than Getz Equipment Innovators components excludes all written and implied liabilities.