

WB-UAD Utility Access Door



REPRESENTED BY _____

DETAIL & SUBMITTAL SHEET

Project: _____ **Date:** _____
Specification Reference: _____
Contractor: _____
Architect: _____

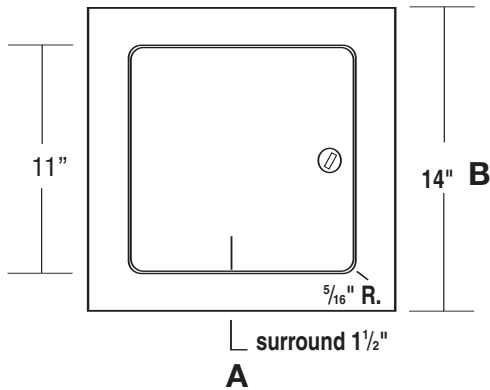

ELEVATION

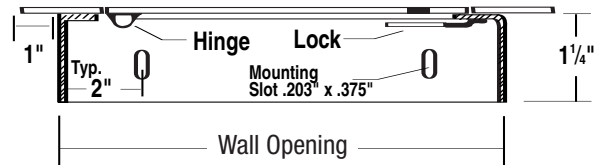

SECTION DETAIL

CONSTRUCTION FEATURES:

- Door and Trim:** 16 ga. steel. Trim being 1-1/2" wide.
- Return Frame:** 16 ga. steel having a depth of 1-1/4".
- Hinge:** One piece hidden pivot rod hinge.
- Latches:** Flush, stainless steel cam operated with screwdriver. Latches are positioned opposite hinge as well as top and bottom on larger sizes.
- Finish:** Electrostatically applied baked grey enamel coat over rust-inhibiting phosphate treated steel. This coating can be used as a finish or as a prime coating.
- Packaging:** By the case; 5 doors per case, except 24" x 24" size — 3 per case, or individually boxed.
- Optional Available: (AT EXTRA COST)**
 - Keyed Cylinder Lock with 2 keys
 - Stainless Steel #304

A B Door Size	Wall Opening	Hinges	Cam Latch	Shipping Wt. Lbs.	Door Case
6"x6"	6 1/8"x6 1/8"	1	1	1 1/2	8 1/2
8"x8"	8 1/8"x8 1/8"	1	1	2 1/2	13 1/2
10"x10"	10 1/8"x10 1/8"	1	1	4	21
12"x12"	12 1/8"x12 1/8"	1	1	5	26
14"x14"	14 1/8"x14 1/8"	1	3	6	32
16"x16"	16 1/8"x16 1/8"	1	3	7 1/2	39 1/2
18"x18"	18 1/8"x18 1/8"	1	3	9	48
24"x24"	24 1/8"x24 1/8"	1	4	15	45



THE WILLIAMS BROTHERS CORPORATION

Corporate Office:
 777 Tapscott Rd.
 Scarborough, Ontario
 M1X 1A2

Phone: (416) 299-7767
 Fax: (416) 299-8039
 Toll free tel.: 1-888-575-1132
 Toll free fax: 1-888-575-1134

www.williams-brothers.com
sales@williams-brothers.com