

STROBE LIGHT

CAT. **SL177A**



SMART STROBE

Separate flash patterns to distinguish between smoke and carbon monoxide.

177 CANDELA XENON STROBE

Powerful 177 candela xenon strobe light provides effective visual warning to deaf & hard of hearing residents.

1 Hz FLASH RATE

60 flashes per minute rate meets UL 1971 /ULC-S526 requirements for visual signal devices.

BRK[®]

THE PROFESSIONAL STANDARD

120V AC, 60Hz Wire-in

Description:

BRK Model SL177 is a hearing impaired strobe light specifically designed for residential and institutional applications including sleeping rooms of hospitals, hotels, motels, dormitories, and other multifamily dwellings. Model SL177 has been fully tested and complies with UL1971/ULC-S526 and with model building codes published by the ICC and OBC.

BRK Model SL177 is a state of the art Strobe Light designed to provide hearing impaired individuals with a visual warning of a fire or a carbon monoxide danger when used with smoke, heat or carbon monoxide alarms. The Smart Strobe has separate flash patterns to distinguish between smoke/heat and carbon monoxide dangers. These different patterns are to help a deaf & hard of hearing person better distinguish the danger present. The 177 candela Xenon strobe meets UL1971/ULC-S526 requirements and flashes at a rate of an average of 60 times a minute.

The SL177 operates on 120V AC and features a green LED that signals the unit is receiving power. Interconnectable with up to 18 devices, of which 12 can be smoke alarms. Model SL177 was designed with quick and easy installation in mind. Designed to cover most drywall cut-outs, the specially designed mounting bracket mounts on any electrical box up to 4" octagonal and does not require screw removal. Connection to AC power is made with a "Quick-Connect" wiring harness.



CAT. SL177A

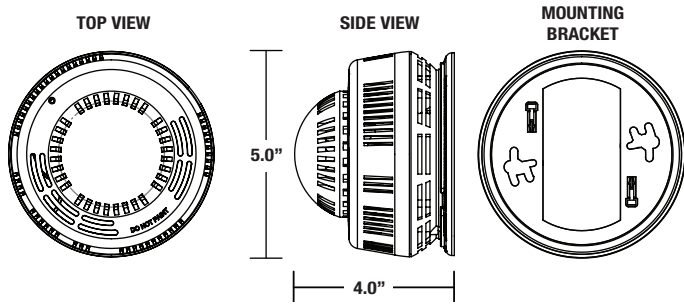

UL1971/ULC-S526 Signaling Devices Light Dispersion Chart

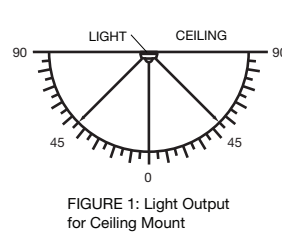

FIGURE 1: Light Output for Ceiling Mount

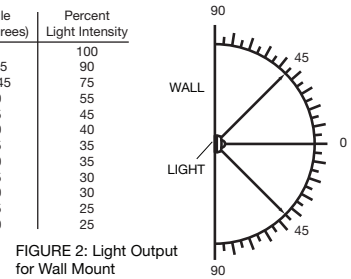

FIGURE 2: Light Output for Wall Mount

ARCHITECTURAL AND ENGINEERING SPEC

The strobe light shall be a BRK Model SL177 and shall provide at a minimum the following features and functions:

1. A 177 candela Xenon strobe.
2. The strobe light shall be powered by 120V AC.
3. The Smart Strobe shall have separate flash patterns to distinguish between smoke/heat and carbon monoxide dangers.
4. A visual LED (green) power-on indicator to confirm the unit is receiving AC power.
5. The unit shall be capable of operating between 32°F (0°C) to 120°F (49°C) and relative humidity of 10% and 90%.
6. The unit shall mount to any standard electrical box up to 4" octagonal without screw removal and shall be listed for ceiling or wall mounting.
7. The unit shall have a plug-in connector and be capable of interconnection up to 18 multiple station alarms.
8. The unit shall at a minimum meet the requirements of UL1971/ULC-S526, the ICC and the OBC.

TECHNICAL SPECS

Alarm Dimensions:	5.1" dia x 4.0"H
Weight:	6.4 oz
Operating Voltage:	120V AC 60Hz
	Voltage Range: 108V AC to 132V AC
Operating Current:	0.05/0.60 amps (standby/alarm)
Temperature Range:	32°F (0°C) to 120°F (49°C)
Humidity Range:	10% to 90% relative humidity (RH)
Interconnections:	Up to 18 units of First Alert or BRK Smoke, CO and Heat Alarms. Maximum of 12 smoke alarms. See user's manual for details.
Test:	To test this strobe light you must activate the test button of each inter-connected, smoke, CO or heat alarm.
Strobe Light:	177 candela Xenon strobe
Flash Rate:	1 Hz.
Smoke/Heat Alarm:	(if connected) Constant approx. 1 flash per second.
CO Alarm:	(if connected) Intermittent approx. 1 flash per second for four flashes, then 5 seconds off. Pattern is repeated.
Indicator Lights:	
AC Power:	Constant Green LED
Listing:	Listed to UL1971/ULC-S526 Standards

SHIPPING SPECS

Individual Carton Dimensions	5.25"L x 4.13"W x 5.44"H
Weight	0.85 lbs.
Cube	0.07 ft3
UPC	029054015464
Master Carton Dimensions	12.63"L x 5.81"W x 5.94"H
Master Pack	3
Weight	2.91 lbs.
Cube:	0.25 ft3
I2of5:	30029054015465
Pallet Information	
Cases per Layer	24
Number of Layers:	7
Cases per Pallet:	168
Units per Pallet:	504
Cube:	47.5 ft3
Weight:	554 lbs.

INSTALLATION OF ALARM

Interconnected units must meet the following requirements: Total length of wire interconnecting units should be less than 1000 feet, be #18 gauge or larger and be rated at least 300V. It is recommended that all units be on the same fuse or circuit breaker. If local codes do not permit, be sure the neutral wire is common to both phases.

THE PARTS OF THIS STROBE LIGHT

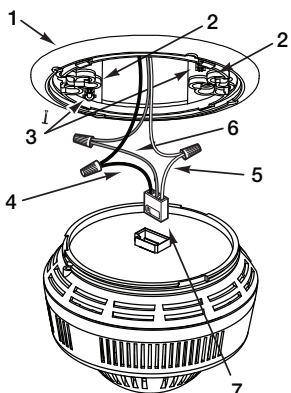

1. Mounting bracket
2. Mounting Slots
3. Locking Pins
4. Hot (Black) AC Wire
5. Neutral (White) AC Wire
6. Interconnect (Orange) Wire
7. Quick-Connect Plug

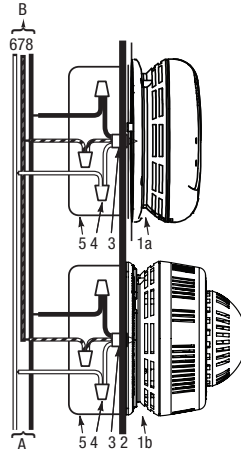

- A. Unswitched 120VAC 60 Hz source
 B. To additional units; Maximum = 18 total (Maximum 12 Smoke Alarms)
- 1a. Smoke Alarm
 - 1b. Strobe Light
 2. Ceiling or Wall
 3. Power Connector
 4. Wire Nut
 5. Electrical Box
 6. Neutral Wire (White)
 7. Interconnect Wire (Orange)
 8. Hot Wire (Black)



BRK is a registered trademark of BRK Brands, Inc. All rights reserved.
brkcanada.ca